

# UniHUB: Open Stack-based platform for integrated research, development and education

*Sergei Strijhak, Ph.D., Researcher  
strijhak@yandex.ru*

*27.06.2016*

# Contents

- Introduction
- ISPRAS and web-laboratory UniHUB
- OpenFoam library, our solver and some cases
- Other research work
- Education
- Possible topics for collaboration
- Conclusions



# ISP RAS

[www.ispras.ru/en](http://www.ispras.ru/en)

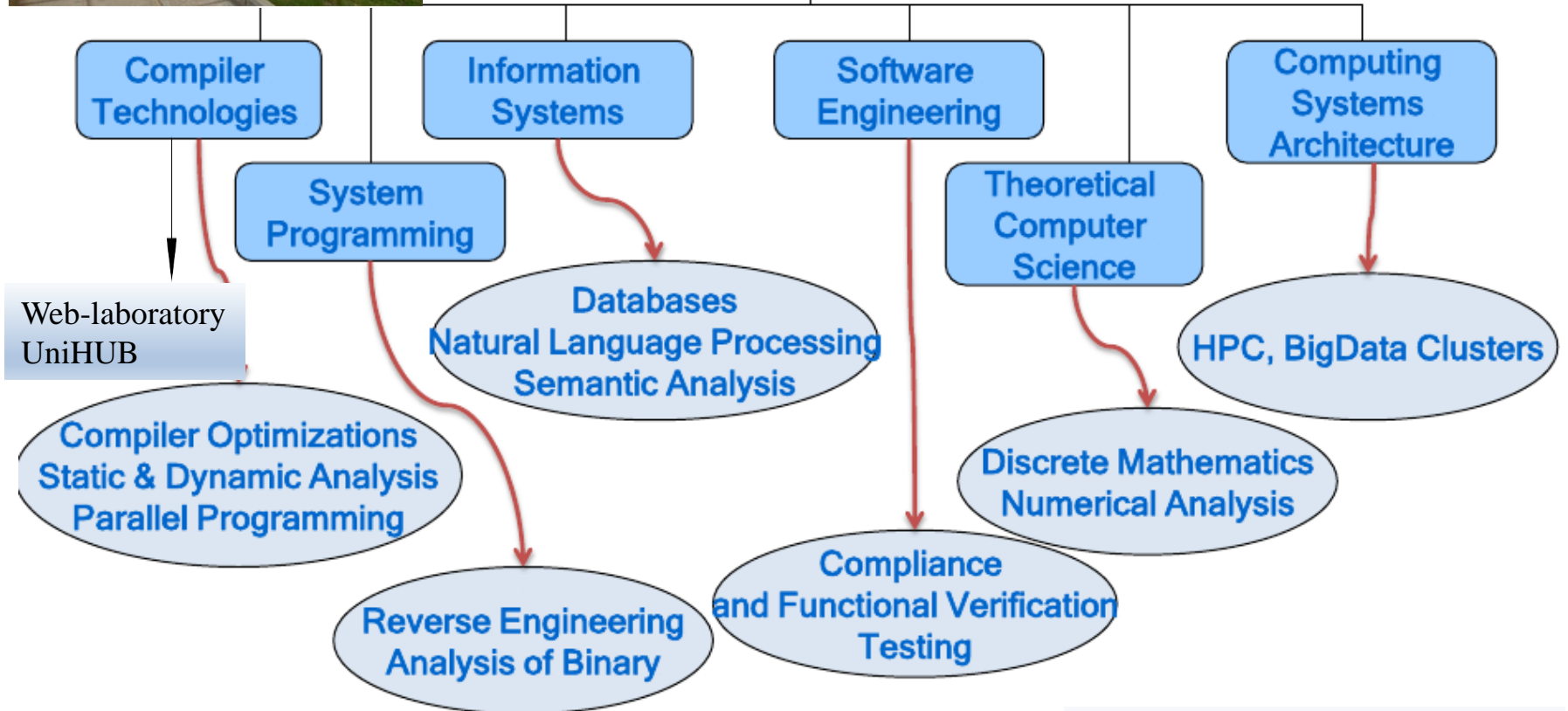

- Research
- Education
- Industry

ISP RAS was founded on  
January 25, 1994

240 employees: 60 Ph.D.  
and 15 Professors  
3 departments of  
MSU, MIPT, HSE

# Ecosystem of ISP RAS is based on the knowledge triangle

Research-oriented  
education

Academician & Industrial  
Advanced Research

Innovation via companies

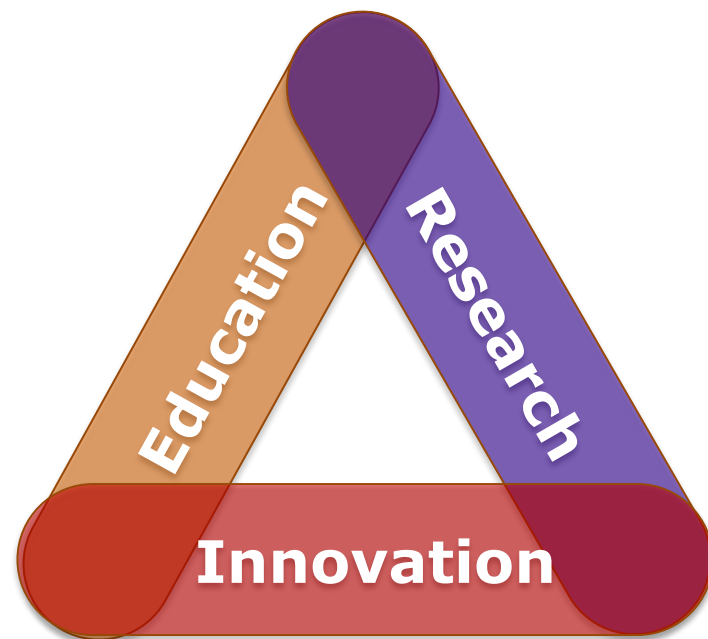

**Long term cooperation with industrial partners:  
HPE, Samsung, Dell, Nvidia, Klocwork (now – RogueWave),  
etc.**

# ISPRAS: compilers and HPC direction

- ❑ GCC optimizations:
  - ✓ New aggressive scheduler with register renaming/speculation/predication support and software pipelining support (4% improvement on SPEC FP 2000 on IA-64)
  - ✓ GCC Modulo Scheduling improvements
  - ✓ Propagating alias information to the machine dependent optimizations (jointly with Richard Guenther from SuSE)
- ❑ Natural language processing tools for Taming Information Explosion (Texterra) and Semi-automatic data extraction from tables
- ❑ HPC direction and cluster's installations:
  - ✓ National Academy of Sciences of the Republic of Armenia (the most powerful on Caucasian region) ;
  - ✓ Oil company «LUKOIL»;
  - ✓ Moscow Institute of Physics and Technology (29 edition Top500);
  - ✓ Vyatka State University (30 edition Top500);
  - ✓ North-Eastern Federal University in Yakutsk (the most powerful on Far East region of Russia)
- ❑ We represented RAS in global technical communities initiated by HPE: Gelato, OpenCirrus

# University Cluster program

## Founders:



- Founded in 2008
- ISP RAS is Competence Center
- Technologies and education in parallel and distributed programming
- Creating technology specific web-laboratories
- Transfer of knowledge into Russian industry

## Partners:

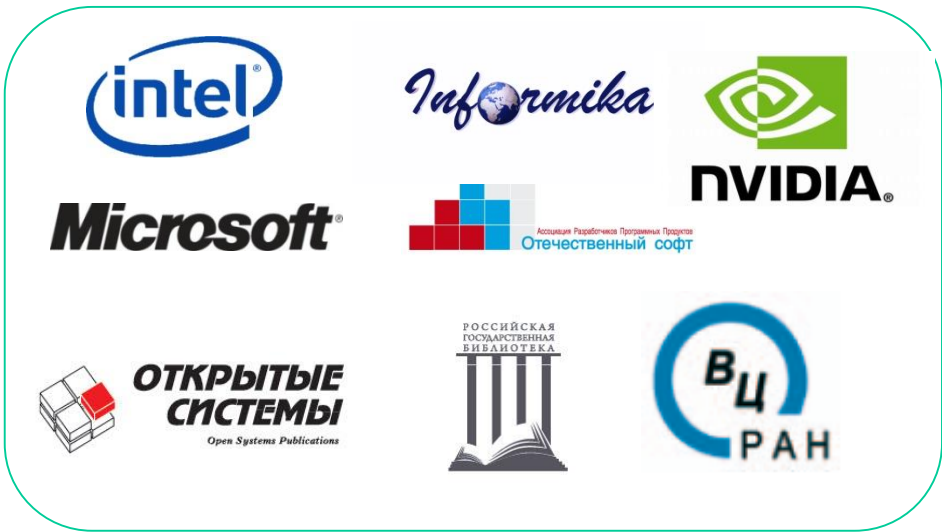

# Technological platform of “University Cluster” program

UniHUB\* – OpenStack-based platform for creating problem-oriented web-labs:

- ❑ Users collaboration (webinars, wiki, trainings, forum, animated presentations, uploading and sharing materials, statistics and user feedback)
- ❑ Simulation tools delivered to browser
- ❑ Software development (IDE, source code control, bug tracking)

OpenStack, SPICE, Apache, Joomla, MediaWiki, FUDforum, Openqwaq, MOOC, Eclipse, Git, Bugzilla, MongoDB, RabbitMQ, Globus Toolkit, Slurm, Python.

\*Availability – 24/7 (Data Center of CC RAS – former Yandex)

# OpenSource: OpenFOAM



Research



Education

Open Source  
(OpenFOAM)

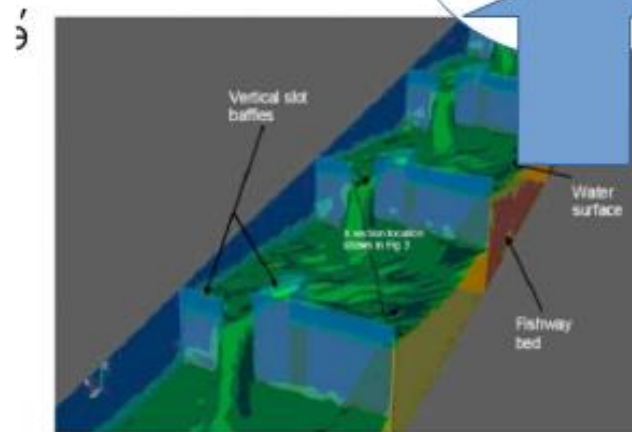

Дамба. H=80 м. 200 Австралия. 2009. Сетка 200 блоков.

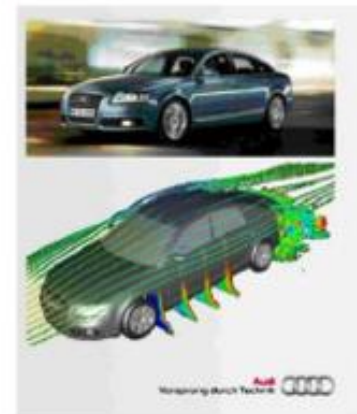

Audi A6. 2009. Сетка 47 М. 128-192 ядер.

Industry



# Web-laboratory UniHUB

Start: 15 march 2011 г.

**The goal:** Building of Russian scientific community, users of Open Source software

**Specialization:**

- 1) *High-temperature gas dynamics and plasma;*
- 2) *Multiphase flows and coupled problems of mechanics;*
- 3) *Projects in the field of space technologies;*
- 4) *Methods of processing and analysis of Big Data;*

Software: SALOME (*pre-processor*), OpenFOAM (solvers), ParaView (*post-processor*), Dakota, Calculix, Elmer, Incompact3D, NEK5000, BEM++ etc.

More than **3000** users are registered on 01.09.2015 in Web-Lab UniHUB.

UniCFD group has **930** users

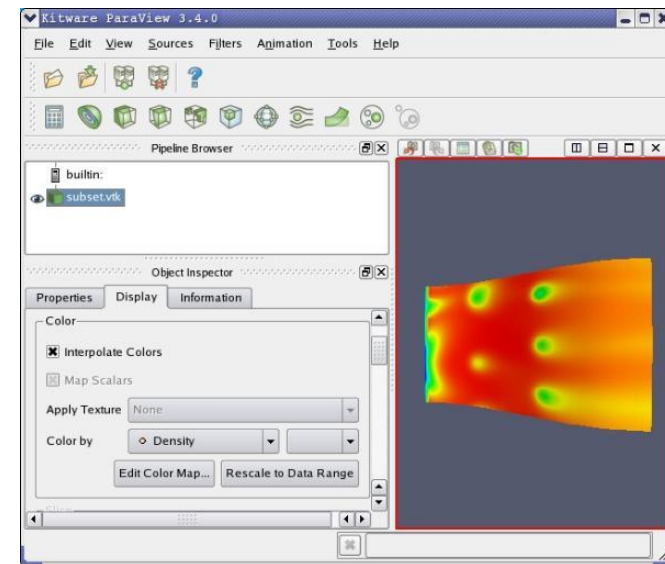
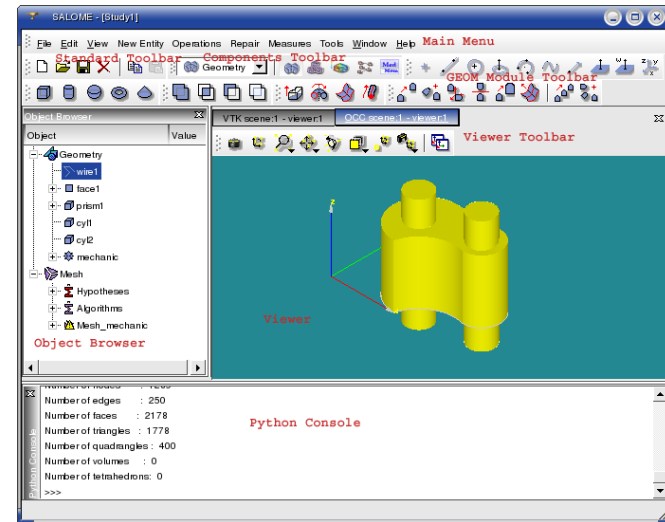

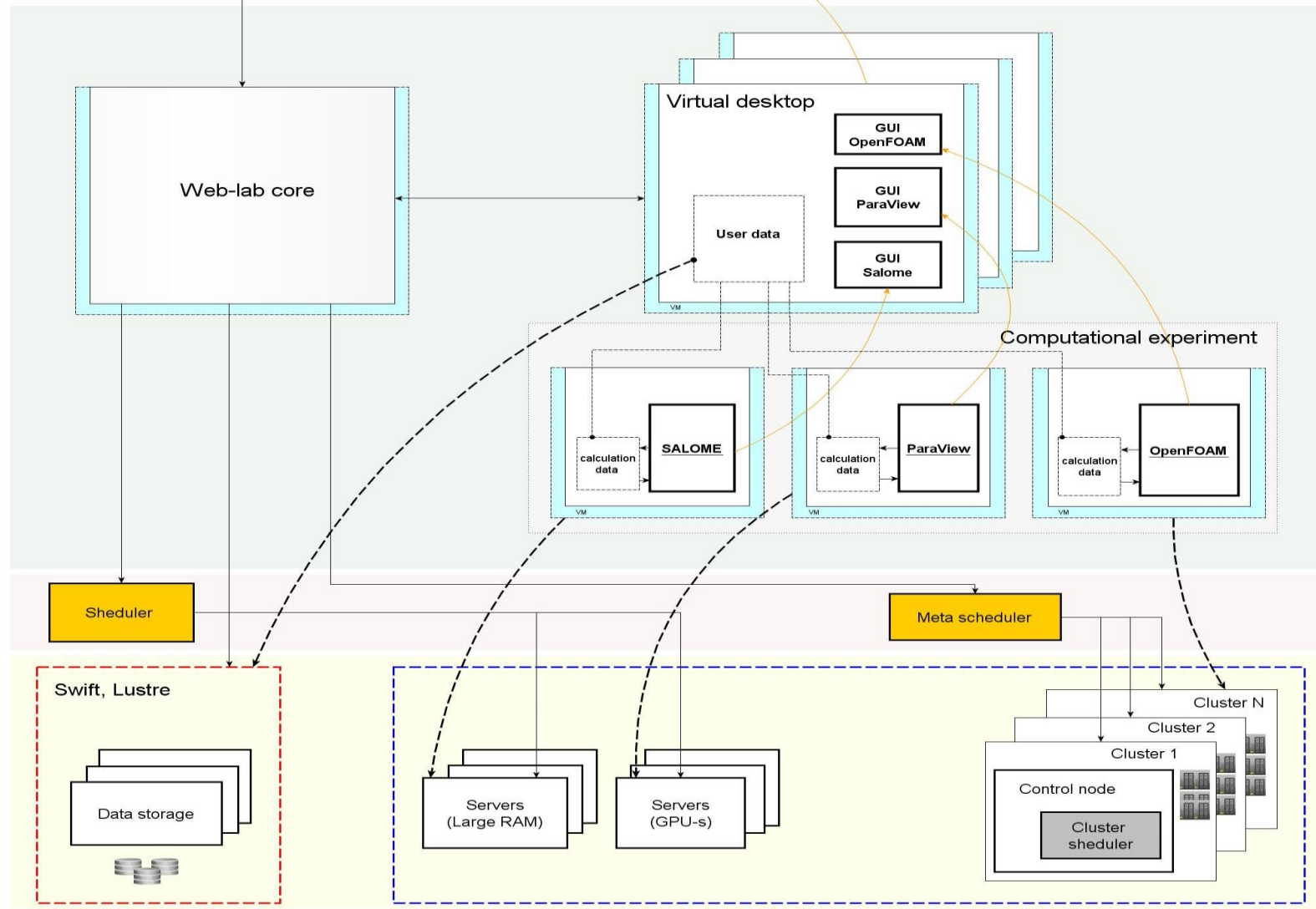
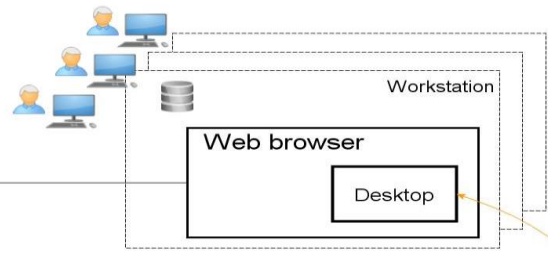

Web-Lab

IaaS

Наши ресурсы доступны  
Ваших задач в режиме

Однако нам удается экономить энергию, разработанным алгоритмам динамически неиспользуемых вычислительных узлов, уверенны в том, что в любой момент времени ровно столько узлов, сколько необход...

РЕСУРСЫ

- Найти
- Популярные теги: UniCFDc1 Open SALOME WebDAV System W ParaView tool: salome CUDA G unihub usage MPI MapReduce "University Cluster" program Unicl HDF5 Open CAD-CAE tool.js3cc PBS aerogasdynamics Office e

Учебные курсы, Файлы, Публикации ресурсов, Обучающие материалы, Конференции... Все категории >

Добавить свой материал: присту

Помощь

- База знаний
- Сообщить об ошибке
- Связаться с нами

Virtual Desktop

Приложение Вопросы О приложениях Обновить В отдельном окне Закрыть

debian SALOME 6.6.0 - [compressor\_v\_sbores\_mesh] xterm 12:30 May

SALOME 6.6.0 - [compressor\_v\_sbores\_mesh]

VTK scene:1 - viewer:1

xterm

```

oleg.samovarov@jx0.unicluster.ru:/lustre/unicluster/home/oleg.samovarov$ /opt/maui/bin/showq
ACTIVE JOBS-----
JOBNAME      USERNAME    STATE  PROC  REMAINING      STARTTIME
4979         u.chushechk Running  8  -INFINITY  Tue May 13 18:16:59
5190         n.dimitrieva Running  8  11:02:57  Tue May 27 23:30:08
5199         y.zagumennii Running  8  2:22:43:42  Thu May 29 11:10:53
5203         y.zagumennii Running  32  3:13:10:18  Fri May 30 01:37:29
5131         i.evдокinov Running  24  35:14:25:47  Fri May 23 10:52:58
5194         i.evдокinov Running  24  40:16:04:17  Wed May 28 12:31:28

  6 Active Jobs   104 of 612 Processors Active (16.99%)
                   12 of 51 Nodes Active (23.53%)

IDLE JOBS-----
JOBNAME      USERNAME    STATE  PROC  WCLIMIT      QUEUETIME

0 Idle Jobs

BLOCKED JOBS-----
JOBNAME      USERNAME    STATE  PROC  WCLIMIT      QUEUETIME

5204         y.zagumennii Idle    32  4:00:00:00  Fri May 30 02:52:00

Total Jobs: 7 Active Jobs: 6 Idle Jobs: 0 Blocked Jobs: 1
oleg.samovarov@jx0.unicluster.ru:/lustre/unicluster/home/oleg.samovarov$
    
```

1403 x 888

Разделить сессию с пользователями (введите их имена через запятую):   Только для просмотра?  Разделить (В данный момент сессия не разделена)

Что значит разделить сессию?

# UniHUB 2.0: <http://desktop.weblab.cloud.unihub.ru/login>

The screenshot displays a web-based desktop interface. At the top, there is a menu bar with 'File', 'Edit', 'View', 'Favorites', 'Tools', and 'Help'. Below it is a toolbar with icons for home, refresh, print, and other functions. The main area is divided into three sections:

- Left Panel:** A sidebar with application icons including 'Home', 'jssc.sh', 'File System', 'bl460.sh', and 'bl220.sh'.
- Terminal Window:** A window titled 'mc [sergei.strijhak@vcn.unicluster.ru]:/lustre/unicluster/home/sergei.strijhak (on vcn.unicluster.ru)'. It shows two side-by-side file listings:
 

| Left Panel  | Right Panel |              |             |    |         |              |            |      |             |        |      |             |         |      |             |          |      |             |        |      |            |           |      |            |        |      |              |              |      |             |         |      |              |          |      |              |          |      |             |          |      |             |                  |      |             |                    |      |             |        |      |             |         |      |             |            |      |            |         |      |            |              |      |              |      |      |             |           |      |            |            |      |             |      |      |             |       |      |             |         |      |            |       |      |             |              |      |            |              |      |             |       |      |             |                 |      |             |           |      |            |            |      |             |        |      |            |                |      |            |  |      |      |             |    |         |             |              |      |            |                    |      |            |            |      |            |              |      |            |                       |      |            |           |      |            |                |      |            |                                |      |            |
|---|-------------|--------------|-------------|----|---------|--------------|------------|------|-------------|--------|------|-------------|---------|------|-------------|----------|------|-------------|--------|------|------------|-----------|------|------------|--------|------|--------------|--------------|------|-------------|---------|------|--------------|----------|------|--------------|----------|------|-------------|----------|------|-------------|------------------|------|-------------|--------------------|------|-------------|--------|------|-------------|---------|------|-------------|------------|------|------------|---------|------|------------|--------------|------|--------------|------|------|-------------|-----------|------|------------|------------|------|-------------|------|------|-------------|-------|------|-------------|---------|------|------------|-------|------|-------------|--------------|------|------------|--------------|------|-------------|-------|------|-------------|-----------------|------|-------------|-----------|------|------------|------------|------|-------------|--------|------|------------|----------------|------|------------|--|------|------|-------------|----|---------|-------------|--------------|------|------------|--------------------|------|------------|------------|------|------------|--------------|------|------------|-----------------------|------|------------|-----------|------|------------|----------------|------|------------|--------------------------------|------|------------|
| <table border="1"> <thead> <tr> <th>Name</th> <th>Size</th> <th>Modify time</th> </tr> </thead> <tbody> <tr><td>..</td><td>UP--DIR</td><td>Mar 31 17:24</td></tr> <tr><td>./OpenFOAM</td><td>4096</td><td>Jun 25 2015</td></tr> <tr><td>./bepp</td><td>4096</td><td>Mar 4 17:26</td></tr> <tr><td>./cache</td><td>4096</td><td>Mar 4 16:50</td></tr> <tr><td>./config</td><td>4096</td><td>Mar 4 16:50</td></tr> <tr><td>./dbus</td><td>4096</td><td>Apr 3 2015</td></tr> <tr><td>./eclipse</td><td>4096</td><td>Jun 2 2011</td></tr> <tr><td>./fltk</td><td>4096</td><td>Oct 26 16:32</td></tr> <tr><td>./fontconfig</td><td>4096</td><td>Nov 20 2013</td></tr> <tr><td>./gconf</td><td>4096</td><td>Mar 23 15:48</td></tr> <tr><td>./gconfd</td><td>4096</td><td>Mar 23 15:49</td></tr> <tr><td>./globus</td><td>4096</td><td>Oct 25 2010</td></tr> <tr><td>./gnome2</td><td>4096</td><td>Feb 3 17:43</td></tr> <tr><td>./gnome2_private</td><td>4096</td><td>Dec 13 2011</td></tr> <tr><td>./gststreamer-0.10</td><td>4096</td><td>Jul 30 2015</td></tr> <tr><td>./gvfs</td><td>4096</td><td>Apr 27 2015</td></tr> <tr><td>./icccm</td><td>4096</td><td>Feb 16 2011</td></tr> <tr><td>./idesktop</td><td>4096</td><td>Sep 4 2014</td></tr> <tr><td>./local</td><td>4096</td><td>Apr 3 2015</td></tr> <tr><td>./matplotlib</td><td>4096</td><td>Mar 30 18:44</td></tr> <tr><td>./mc</td><td>4096</td><td>Apr 2 14:38</td></tr> <tr><td>./mozilla</td><td>4096</td><td>Apr 6 2015</td></tr> <tr><td>./nautilus</td><td>4096</td><td>Apr 21 2015</td></tr> <tr><td>./nv</td><td>4096</td><td>Mar 18 2015</td></tr> <tr><td>./pki</td><td>4096</td><td>Sep 23 2015</td></tr> <tr><td>./pulse</td><td>4096</td><td>Apr 3 2015</td></tr> <tr><td>./ssh</td><td>4096</td><td>Mar 16 2015</td></tr> <tr><td>./subversion</td><td>4096</td><td>Jul 9 2013</td></tr> <tr><td>./thumbnails</td><td>4096</td><td>Jul 28 2013</td></tr> <tr><td>./vnc</td><td>4096</td><td>Dec 10 2010</td></tr> <tr><td>./wakeScheduler</td><td>4096</td><td>Jul 29 2012</td></tr> <tr><td>./2013ot1</td><td>4096</td><td>Oct 5 2013</td></tr> <tr><td>./2013Nir2</td><td>4096</td><td>Jul 28 2013</td></tr> <tr><td>./2014</td><td>4096</td><td>Aug 8 2014</td></tr> <tr><td>./2014_Energia</td><td>4096</td><td>Nov 9 2014</td></tr> </tbody> </table> | Name        | Size         | Modify time | .. | UP--DIR | Mar 31 17:24 | ./OpenFOAM | 4096 | Jun 25 2015 | ./bepp | 4096 | Mar 4 17:26 | ./cache | 4096 | Mar 4 16:50 | ./config | 4096 | Mar 4 16:50 | ./dbus | 4096 | Apr 3 2015 | ./eclipse | 4096 | Jun 2 2011 | ./fltk | 4096 | Oct 26 16:32 | ./fontconfig | 4096 | Nov 20 2013 | ./gconf | 4096 | Mar 23 15:48 | ./gconfd | 4096 | Mar 23 15:49 | ./globus | 4096 | Oct 25 2010 | ./gnome2 | 4096 | Feb 3 17:43 | ./gnome2_private | 4096 | Dec 13 2011 | ./gststreamer-0.10 | 4096 | Jul 30 2015 | ./gvfs | 4096 | Apr 27 2015 | ./icccm | 4096 | Feb 16 2011 | ./idesktop | 4096 | Sep 4 2014 | ./local | 4096 | Apr 3 2015 | ./matplotlib | 4096 | Mar 30 18:44 | ./mc | 4096 | Apr 2 14:38 | ./mozilla | 4096 | Apr 6 2015 | ./nautilus | 4096 | Apr 21 2015 | ./nv | 4096 | Mar 18 2015 | ./pki | 4096 | Sep 23 2015 | ./pulse | 4096 | Apr 3 2015 | ./ssh | 4096 | Mar 16 2015 | ./subversion | 4096 | Jul 9 2013 | ./thumbnails | 4096 | Jul 28 2013 | ./vnc | 4096 | Dec 10 2010 | ./wakeScheduler | 4096 | Jul 29 2012 | ./2013ot1 | 4096 | Oct 5 2013 | ./2013Nir2 | 4096 | Jul 28 2013 | ./2014 | 4096 | Aug 8 2014 | ./2014_Energia | 4096 | Nov 9 2014 | <table border="1"> <thead> <tr> <th>Name</th> <th>Size</th> <th>Modify time</th> </tr> </thead> <tbody> <tr><td>..</td><td>UP--DIR</td><td>May 22 2015</td></tr> <tr><td>./simpleFoam</td><td>4096</td><td>Jul 7 2015</td></tr> <tr><td>./shallowWaterFoam</td><td>4096</td><td>Jul 7 2015</td></tr> <tr><td>./pisoFoam</td><td>4096</td><td>Jul 7 2015</td></tr> <tr><td>./pimpleFoam</td><td>4096</td><td>Jul 7 2015</td></tr> <tr><td>./nonNewtonianIcoFoam</td><td>4096</td><td>Jul 7 2015</td></tr> <tr><td>./icoFoam</td><td>4096</td><td>Jul 7 2015</td></tr> <tr><td>./boundaryFoam</td><td>4096</td><td>Jul 7 2015</td></tr> <tr><td>./adjointShapeOptimizationFoam</td><td>4096</td><td>Jul 7 2015</td></tr> </tbody> </table> | Name | Size | Modify time | .. | UP--DIR | May 22 2015 | ./simpleFoam | 4096 | Jul 7 2015 | ./shallowWaterFoam | 4096 | Jul 7 2015 | ./pisoFoam | 4096 | Jul 7 2015 | ./pimpleFoam | 4096 | Jul 7 2015 | ./nonNewtonianIcoFoam | 4096 | Jul 7 2015 | ./icoFoam | 4096 | Jul 7 2015 | ./boundaryFoam | 4096 | Jul 7 2015 | ./adjointShapeOptimizationFoam | 4096 | Jul 7 2015 |
| Name  | Size        | Modify time  |             |    |         |              |            |      |             |        |      |             |         |      |             |          |      |             |        |      |            |           |      |            |        |      |              |              |      |             |         |      |              |          |      |              |          |      |             |          |      |             |                  |      |             |                    |      |             |        |      |             |         |      |             |            |      |            |         |      |            |              |      |              |      |      |             |           |      |            |            |      |             |      |      |             |       |      |             |         |      |            |       |      |             |              |      |            |              |      |             |       |      |             |                 |      |             |           |      |            |            |      |             |        |      |            |                |      |            |  |      |      |             |    |         |             |              |      |            |                    |      |            |            |      |            |              |      |            |                       |      |            |           |      |            |                |      |            |                                |      |            |
| ..  | UP--DIR     | Mar 31 17:24 |             |    |         |              |            |      |             |        |      |             |         |      |             |          |      |             |        |      |            |           |      |            |        |      |              |              |      |             |         |      |              |          |      |              |          |      |             |          |      |             |                  |      |             |                    |      |             |        |      |             |         |      |             |            |      |            |         |      |            |              |      |              |      |      |             |           |      |            |            |      |             |      |      |             |       |      |             |         |      |            |       |      |             |              |      |            |              |      |             |       |      |             |                 |      |             |           |      |            |            |      |             |        |      |            |                |      |            |  |      |      |             |    |         |             |              |      |            |                    |      |            |            |      |            |              |      |            |                       |      |            |           |      |            |                |      |            |                                |      |            |
| ./OpenFOAM  | 4096        | Jun 25 2015  |             |    |         |              |            |      |             |        |      |             |         |      |             |          |      |             |        |      |            |           |      |            |        |      |              |              |      |             |         |      |              |          |      |              |          |      |             |          |      |             |                  |      |             |                    |      |             |        |      |             |         |      |             |            |      |            |         |      |            |              |      |              |      |      |             |           |      |            |            |      |             |      |      |             |       |      |             |         |      |            |       |      |             |              |      |            |              |      |             |       |      |             |                 |      |             |           |      |            |            |      |             |        |      |            |                |      |            |  |      |      |             |    |         |             |              |      |            |                    |      |            |            |      |            |              |      |            |                       |      |            |           |      |            |                |      |            |                                |      |            |
| ./bepp  | 4096        | Mar 4 17:26  |             |    |         |              |            |      |             |        |      |             |         |      |             |          |      |             |        |      |            |           |      |            |        |      |              |              |      |             |         |      |              |          |      |              |          |      |             |          |      |             |                  |      |             |                    |      |             |        |      |             |         |      |             |            |      |            |         |      |            |              |      |              |      |      |             |           |      |            |            |      |             |      |      |             |       |      |             |         |      |            |       |      |             |              |      |            |              |      |             |       |      |             |                 |      |             |           |      |            |            |      |             |        |      |            |                |      |            |  |      |      |             |    |         |             |              |      |            |                    |      |            |            |      |            |              |      |            |                       |      |            |           |      |            |                |      |            |                                |      |            |
| ./cache   | 4096        | Mar 4 16:50  |             |    |         |              |            |      |             |        |      |             |         |      |             |          |      |             |        |      |            |           |      |            |        |      |              |              |      |             |         |      |              |          |      |              |          |      |             |          |      |             |                  |      |             |                    |      |             |        |      |             |         |      |             |            |      |            |         |      |            |              |      |              |      |      |             |           |      |            |            |      |             |      |      |             |       |      |             |         |      |            |       |      |             |              |      |            |              |      |             |       |      |             |                 |      |             |           |      |            |            |      |             |        |      |            |                |      |            |  |      |      |             |    |         |             |              |      |            |                    |      |            |            |      |            |              |      |            |                       |      |            |           |      |            |                |      |            |                                |      |            |
| ./config  | 4096        | Mar 4 16:50  |             |    |         |              |            |      |             |        |      |             |         |      |             |          |      |             |        |      |            |           |      |            |        |      |              |              |      |             |         |      |              |          |      |              |          |      |             |          |      |             |                  |      |             |                    |      |             |        |      |             |         |      |             |            |      |            |         |      |            |              |      |              |      |      |             |           |      |            |            |      |             |      |      |             |       |      |             |         |      |            |       |      |             |              |      |            |              |      |             |       |      |             |                 |      |             |           |      |            |            |      |             |        |      |            |                |      |            |  |      |      |             |    |         |             |              |      |            |                    |      |            |            |      |            |              |      |            |                       |      |            |           |      |            |                |      |            |                                |      |            |
| ./dbus  | 4096        | Apr 3 2015   |             |    |         |              |            |      |             |        |      |             |         |      |             |          |      |             |        |      |            |           |      |            |        |      |              |              |      |             |         |      |              |          |      |              |          |      |             |          |      |             |                  |      |             |                    |      |             |        |      |             |         |      |             |            |      |            |         |      |            |              |      |              |      |      |             |           |      |            |            |      |             |      |      |             |       |      |             |         |      |            |       |      |             |              |      |            |              |      |             |       |      |             |                 |      |             |           |      |            |            |      |             |        |      |            |                |      |            |  |      |      |             |    |         |             |              |      |            |                    |      |            |            |      |            |              |      |            |                       |      |            |           |      |            |                |      |            |                                |      |            |
| ./eclipse   | 4096        | Jun 2 2011   |             |    |         |              |            |      |             |        |      |             |         |      |             |          |      |             |        |      |            |           |      |            |        |      |              |              |      |             |         |      |              |          |      |              |          |      |             |          |      |             |                  |      |             |                    |      |             |        |      |             |         |      |             |            |      |            |         |      |            |              |      |              |      |      |             |           |      |            |            |      |             |      |      |             |       |      |             |         |      |            |       |      |             |              |      |            |              |      |             |       |      |             |                 |      |             |           |      |            |            |      |             |        |      |            |                |      |            |  |      |      |             |    |         |             |              |      |            |                    |      |            |            |      |            |              |      |            |                       |      |            |           |      |            |                |      |            |                                |      |            |
| ./fltk  | 4096        | Oct 26 16:32 |             |    |         |              |            |      |             |        |      |             |         |      |             |          |      |             |        |      |            |           |      |            |        |      |              |              |      |             |         |      |              |          |      |              |          |      |             |          |      |             |                  |      |             |                    |      |             |        |      |             |         |      |             |            |      |            |         |      |            |              |      |              |      |      |             |           |      |            |            |      |             |      |      |             |       |      |             |         |      |            |       |      |             |              |      |            |              |      |             |       |      |             |                 |      |             |           |      |            |            |      |             |        |      |            |                |      |            |  |      |      |             |    |         |             |              |      |            |                    |      |            |            |      |            |              |      |            |                       |      |            |           |      |            |                |      |            |                                |      |            |
| ./fontconfig  | 4096        | Nov 20 2013  |             |    |         |              |            |      |             |        |      |             |         |      |             |          |      |             |        |      |            |           |      |            |        |      |              |              |      |             |         |      |              |          |      |              |          |      |             |          |      |             |                  |      |             |                    |      |             |        |      |             |         |      |             |            |      |            |         |      |            |              |      |              |      |      |             |           |      |            |            |      |             |      |      |             |       |      |             |         |      |            |       |      |             |              |      |            |              |      |             |       |      |             |                 |      |             |           |      |            |            |      |             |        |      |            |                |      |            |  |      |      |             |    |         |             |              |      |            |                    |      |            |            |      |            |              |      |            |                       |      |            |           |      |            |                |      |            |                                |      |            |
| ./gconf   | 4096        | Mar 23 15:48 |             |    |         |              |            |      |             |        |      |             |         |      |             |          |      |             |        |      |            |           |      |            |        |      |              |              |      |             |         |      |              |          |      |              |          |      |             |          |      |             |                  |      |             |                    |      |             |        |      |             |         |      |             |            |      |            |         |      |            |              |      |              |      |      |             |           |      |            |            |      |             |      |      |             |       |      |             |         |      |            |       |      |             |              |      |            |              |      |             |       |      |             |                 |      |             |           |      |            |            |      |             |        |      |            |                |      |            |  |      |      |             |    |         |             |              |      |            |                    |      |            |            |      |            |              |      |            |                       |      |            |           |      |            |                |      |            |                                |      |            |
| ./gconfd  | 4096        | Mar 23 15:49 |             |    |         |              |            |      |             |        |      |             |         |      |             |          |      |             |        |      |            |           |      |            |        |      |              |              |      |             |         |      |              |          |      |              |          |      |             |          |      |             |                  |      |             |                    |      |             |        |      |             |         |      |             |            |      |            |         |      |            |              |      |              |      |      |             |           |      |            |            |      |             |      |      |             |       |      |             |         |      |            |       |      |             |              |      |            |              |      |             |       |      |             |                 |      |             |           |      |            |            |      |             |        |      |            |                |      |            |  |      |      |             |    |         |             |              |      |            |                    |      |            |            |      |            |              |      |            |                       |      |            |           |      |            |                |      |            |                                |      |            |
| ./globus  | 4096        | Oct 25 2010  |             |    |         |              |            |      |             |        |      |             |         |      |             |          |      |             |        |      |            |           |      |            |        |      |              |              |      |             |         |      |              |          |      |              |          |      |             |          |      |             |                  |      |             |                    |      |             |        |      |             |         |      |             |            |      |            |         |      |            |              |      |              |      |      |             |           |      |            |            |      |             |      |      |             |       |      |             |         |      |            |       |      |             |              |      |            |              |      |             |       |      |             |                 |      |             |           |      |            |            |      |             |        |      |            |                |      |            |  |      |      |             |    |         |             |              |      |            |                    |      |            |            |      |            |              |      |            |                       |      |            |           |      |            |                |      |            |                                |      |            |
| ./gnome2  | 4096        | Feb 3 17:43  |             |    |         |              |            |      |             |        |      |             |         |      |             |          |      |             |        |      |            |           |      |            |        |      |              |              |      |             |         |      |              |          |      |              |          |      |             |          |      |             |                  |      |             |                    |      |             |        |      |             |         |      |             |            |      |            |         |      |            |              |      |              |      |      |             |           |      |            |            |      |             |      |      |             |       |      |             |         |      |            |       |      |             |              |      |            |              |      |             |       |      |             |                 |      |             |           |      |            |            |      |             |        |      |            |                |      |            |  |      |      |             |    |         |             |              |      |            |                    |      |            |            |      |            |              |      |            |                       |      |            |           |      |            |                |      |            |                                |      |            |
| ./gnome2_private  | 4096        | Dec 13 2011  |             |    |         |              |            |      |             |        |      |             |         |      |             |          |      |             |        |      |            |           |      |            |        |      |              |              |      |             |         |      |              |          |      |              |          |      |             |          |      |             |                  |      |             |                    |      |             |        |      |             |         |      |             |            |      |            |         |      |            |              |      |              |      |      |             |           |      |            |            |      |             |      |      |             |       |      |             |         |      |            |       |      |             |              |      |            |              |      |             |       |      |             |                 |      |             |           |      |            |            |      |             |        |      |            |                |      |            |  |      |      |             |    |         |             |              |      |            |                    |      |            |            |      |            |              |      |            |                       |      |            |           |      |            |                |      |            |                                |      |            |
| ./gststreamer-0.10  | 4096        | Jul 30 2015  |             |    |         |              |            |      |             |        |      |             |         |      |             |          |      |             |        |      |            |           |      |            |        |      |              |              |      |             |         |      |              |          |      |              |          |      |             |          |      |             |                  |      |             |                    |      |             |        |      |             |         |      |             |            |      |            |         |      |            |              |      |              |      |      |             |           |      |            |            |      |             |      |      |             |       |      |             |         |      |            |       |      |             |              |      |            |              |      |             |       |      |             |                 |      |             |           |      |            |            |      |             |        |      |            |                |      |            |  |      |      |             |    |         |             |              |      |            |                    |      |            |            |      |            |              |      |            |                       |      |            |           |      |            |                |      |            |                                |      |            |
| ./gvfs  | 4096        | Apr 27 2015  |             |    |         |              |            |      |             |        |      |             |         |      |             |          |      |             |        |      |            |           |      |            |        |      |              |              |      |             |         |      |              |          |      |              |          |      |             |          |      |             |                  |      |             |                    |      |             |        |      |             |         |      |             |            |      |            |         |      |            |              |      |              |      |      |             |           |      |            |            |      |             |      |      |             |       |      |             |         |      |            |       |      |             |              |      |            |              |      |             |       |      |             |                 |      |             |           |      |            |            |      |             |        |      |            |                |      |            |  |      |      |             |    |         |             |              |      |            |                    |      |            |            |      |            |              |      |            |                       |      |            |           |      |            |                |      |            |                                |      |            |
| ./icccm   | 4096        | Feb 16 2011  |             |    |         |              |            |      |             |        |      |             |         |      |             |          |      |             |        |      |            |           |      |            |        |      |              |              |      |             |         |      |              |          |      |              |          |      |             |          |      |             |                  |      |             |                    |      |             |        |      |             |         |      |             |            |      |            |         |      |            |              |      |              |      |      |             |           |      |            |            |      |             |      |      |             |       |      |             |         |      |            |       |      |             |              |      |            |              |      |             |       |      |             |                 |      |             |           |      |            |            |      |             |        |      |            |                |      |            |  |      |      |             |    |         |             |              |      |            |                    |      |            |            |      |            |              |      |            |                       |      |            |           |      |            |                |      |            |                                |      |            |
| ./idesktop  | 4096        | Sep 4 2014   |             |    |         |              |            |      |             |        |      |             |         |      |             |          |      |             |        |      |            |           |      |            |        |      |              |              |      |             |         |      |              |          |      |              |          |      |             |          |      |             |                  |      |             |                    |      |             |        |      |             |         |      |             |            |      |            |         |      |            |              |      |              |      |      |             |           |      |            |            |      |             |      |      |             |       |      |             |         |      |            |       |      |             |              |      |            |              |      |             |       |      |             |                 |      |             |           |      |            |            |      |             |        |      |            |                |      |            |  |      |      |             |    |         |             |              |      |            |                    |      |            |            |      |            |              |      |            |                       |      |            |           |      |            |                |      |            |                                |      |            |
| ./local   | 4096        | Apr 3 2015   |             |    |         |              |            |      |             |        |      |             |         |      |             |          |      |             |        |      |            |           |      |            |        |      |              |              |      |             |         |      |              |          |      |              |          |      |             |          |      |             |                  |      |             |                    |      |             |        |      |             |         |      |             |            |      |            |         |      |            |              |      |              |      |      |             |           |      |            |            |      |             |      |      |             |       |      |             |         |      |            |       |      |             |              |      |            |              |      |             |       |      |             |                 |      |             |           |      |            |            |      |             |        |      |            |                |      |            |  |      |      |             |    |         |             |              |      |            |                    |      |            |            |      |            |              |      |            |                       |      |            |           |      |            |                |      |            |                                |      |            |
| ./matplotlib  | 4096        | Mar 30 18:44 |             |    |         |              |            |      |             |        |      |             |         |      |             |          |      |             |        |      |            |           |      |            |        |      |              |              |      |             |         |      |              |          |      |              |          |      |             |          |      |             |                  |      |             |                    |      |             |        |      |             |         |      |             |            |      |            |         |      |            |              |      |              |      |      |             |           |      |            |            |      |             |      |      |             |       |      |             |         |      |            |       |      |             |              |      |            |              |      |             |       |      |             |                 |      |             |           |      |            |            |      |             |        |      |            |                |      |            |  |      |      |             |    |         |             |              |      |            |                    |      |            |            |      |            |              |      |            |                       |      |            |           |      |            |                |      |            |                                |      |            |
| ./mc  | 4096        | Apr 2 14:38  |             |    |         |              |            |      |             |        |      |             |         |      |             |          |      |             |        |      |            |           |      |            |        |      |              |              |      |             |         |      |              |          |      |              |          |      |             |          |      |             |                  |      |             |                    |      |             |        |      |             |         |      |             |            |      |            |         |      |            |              |      |              |      |      |             |           |      |            |            |      |             |      |      |             |       |      |             |         |      |            |       |      |             |              |      |            |              |      |             |       |      |             |                 |      |             |           |      |            |            |      |             |        |      |            |                |      |            |  |      |      |             |    |         |             |              |      |            |                    |      |            |            |      |            |              |      |            |                       |      |            |           |      |            |                |      |            |                                |      |            |
| ./mozilla   | 4096        | Apr 6 2015   |             |    |         |              |            |      |             |        |      |             |         |      |             |          |      |             |        |      |            |           |      |            |        |      |              |              |      |             |         |      |              |          |      |              |          |      |             |          |      |             |                  |      |             |                    |      |             |        |      |             |         |      |             |            |      |            |         |      |            |              |      |              |      |      |             |           |      |            |            |      |             |      |      |             |       |      |             |         |      |            |       |      |             |              |      |            |              |      |             |       |      |             |                 |      |             |           |      |            |            |      |             |        |      |            |                |      |            |  |      |      |             |    |         |             |              |      |            |                    |      |            |            |      |            |              |      |            |                       |      |            |           |      |            |                |      |            |                                |      |            |
| ./nautilus  | 4096        | Apr 21 2015  |             |    |         |              |            |      |             |        |      |             |         |      |             |          |      |             |        |      |            |           |      |            |        |      |              |              |      |             |         |      |              |          |      |              |          |      |             |          |      |             |                  |      |             |                    |      |             |        |      |             |         |      |             |            |      |            |         |      |            |              |      |              |      |      |             |           |      |            |            |      |             |      |      |             |       |      |             |         |      |            |       |      |             |              |      |            |              |      |             |       |      |             |                 |      |             |           |      |            |            |      |             |        |      |            |                |      |            |  |      |      |             |    |         |             |              |      |            |                    |      |            |            |      |            |              |      |            |                       |      |            |           |      |            |                |      |            |                                |      |            |
| ./nv  | 4096        | Mar 18 2015  |             |    |         |              |            |      |             |        |      |             |         |      |             |          |      |             |        |      |            |           |      |            |        |      |              |              |      |             |         |      |              |          |      |              |          |      |             |          |      |             |                  |      |             |                    |      |             |        |      |             |         |      |             |            |      |            |         |      |            |              |      |              |      |      |             |           |      |            |            |      |             |      |      |             |       |      |             |         |      |            |       |      |             |              |      |            |              |      |             |       |      |             |                 |      |             |           |      |            |            |      |             |        |      |            |                |      |            |  |      |      |             |    |         |             |              |      |            |                    |      |            |            |      |            |              |      |            |                       |      |            |           |      |            |                |      |            |                                |      |            |
| ./pki   | 4096        | Sep 23 2015  |             |    |         |              |            |      |             |        |      |             |         |      |             |          |      |             |        |      |            |           |      |            |        |      |              |              |      |             |         |      |              |          |      |              |          |      |             |          |      |             |                  |      |             |                    |      |             |        |      |             |         |      |             |            |      |            |         |      |            |              |      |              |      |      |             |           |      |            |            |      |             |      |      |             |       |      |             |         |      |            |       |      |             |              |      |            |              |      |             |       |      |             |                 |      |             |           |      |            |            |      |             |        |      |            |                |      |            |  |      |      |             |    |         |             |              |      |            |                    |      |            |            |      |            |              |      |            |                       |      |            |           |      |            |                |      |            |                                |      |            |
| ./pulse   | 4096        | Apr 3 2015   |             |    |         |              |            |      |             |        |      |             |         |      |             |          |      |             |        |      |            |           |      |            |        |      |              |              |      |             |         |      |              |          |      |              |          |      |             |          |      |             |                  |      |             |                    |      |             |        |      |             |         |      |             |            |      |            |         |      |            |              |      |              |      |      |             |           |      |            |            |      |             |      |      |             |       |      |             |         |      |            |       |      |             |              |      |            |              |      |             |       |      |             |                 |      |             |           |      |            |            |      |             |        |      |            |                |      |            |  |      |      |             |    |         |             |              |      |            |                    |      |            |            |      |            |              |      |            |                       |      |            |           |      |            |                |      |            |                                |      |            |
| ./ssh   | 4096        | Mar 16 2015  |             |    |         |              |            |      |             |        |      |             |         |      |             |          |      |             |        |      |            |           |      |            |        |      |              |              |      |             |         |      |              |          |      |              |          |      |             |          |      |             |                  |      |             |                    |      |             |        |      |             |         |      |             |            |      |            |         |      |            |              |      |              |      |      |             |           |      |            |            |      |             |      |      |             |       |      |             |         |      |            |       |      |             |              |      |            |              |      |             |       |      |             |                 |      |             |           |      |            |            |      |             |        |      |            |                |      |            |  |      |      |             |    |         |             |              |      |            |                    |      |            |            |      |            |              |      |            |                       |      |            |           |      |            |                |      |            |                                |      |            |
| ./subversion  | 4096        | Jul 9 2013   |             |    |         |              |            |      |             |        |      |             |         |      |             |          |      |             |        |      |            |           |      |            |        |      |              |              |      |             |         |      |              |          |      |              |          |      |             |          |      |             |                  |      |             |                    |      |             |        |      |             |         |      |             |            |      |            |         |      |            |              |      |              |      |      |             |           |      |            |            |      |             |      |      |             |       |      |             |         |      |            |       |      |             |              |      |            |              |      |             |       |      |             |                 |      |             |           |      |            |            |      |             |        |      |            |                |      |            |  |      |      |             |    |         |             |              |      |            |                    |      |            |            |      |            |              |      |            |                       |      |            |           |      |            |                |      |            |                                |      |            |
| ./thumbnails  | 4096        | Jul 28 2013  |             |    |         |              |            |      |             |        |      |             |         |      |             |          |      |             |        |      |            |           |      |            |        |      |              |              |      |             |         |      |              |          |      |              |          |      |             |          |      |             |                  |      |             |                    |      |             |        |      |             |         |      |             |            |      |            |         |      |            |              |      |              |      |      |             |           |      |            |            |      |             |      |      |             |       |      |             |         |      |            |       |      |             |              |      |            |              |      |             |       |      |             |                 |      |             |           |      |            |            |      |             |        |      |            |                |      |            |  |      |      |             |    |         |             |              |      |            |                    |      |            |            |      |            |              |      |            |                       |      |            |           |      |            |                |      |            |                                |      |            |
| ./vnc   | 4096        | Dec 10 2010  |             |    |         |              |            |      |             |        |      |             |         |      |             |          |      |             |        |      |            |           |      |            |        |      |              |              |      |             |         |      |              |          |      |              |          |      |             |          |      |             |                  |      |             |                    |      |             |        |      |             |         |      |             |            |      |            |         |      |            |              |      |              |      |      |             |           |      |            |            |      |             |      |      |             |       |      |             |         |      |            |       |      |             |              |      |            |              |      |             |       |      |             |                 |      |             |           |      |            |            |      |             |        |      |            |                |      |            |  |      |      |             |    |         |             |              |      |            |                    |      |            |            |      |            |              |      |            |                       |      |            |           |      |            |                |      |            |                                |      |            |
| ./wakeScheduler   | 4096        | Jul 29 2012  |             |    |         |              |            |      |             |        |      |             |         |      |             |          |      |             |        |      |            |           |      |            |        |      |              |              |      |             |         |      |              |          |      |              |          |      |             |          |      |             |                  |      |             |                    |      |             |        |      |             |         |      |             |            |      |            |         |      |            |              |      |              |      |      |             |           |      |            |            |      |             |      |      |             |       |      |             |         |      |            |       |      |             |              |      |            |              |      |             |       |      |             |                 |      |             |           |      |            |            |      |             |        |      |            |                |      |            |  |      |      |             |    |         |             |              |      |            |                    |      |            |            |      |            |              |      |            |                       |      |            |           |      |            |                |      |            |                                |      |            |
| ./2013ot1   | 4096        | Oct 5 2013   |             |    |         |              |            |      |             |        |      |             |         |      |             |          |      |             |        |      |            |           |      |            |        |      |              |              |      |             |         |      |              |          |      |              |          |      |             |          |      |             |                  |      |             |                    |      |             |        |      |             |         |      |             |            |      |            |         |      |            |              |      |              |      |      |             |           |      |            |            |      |             |      |      |             |       |      |             |         |      |            |       |      |             |              |      |            |              |      |             |       |      |             |                 |      |             |           |      |            |            |      |             |        |      |            |                |      |            |  |      |      |             |    |         |             |              |      |            |                    |      |            |            |      |            |              |      |            |                       |      |            |           |      |            |                |      |            |                                |      |            |
| ./2013Nir2  | 4096        | Jul 28 2013  |             |    |         |              |            |      |             |        |      |             |         |      |             |          |      |             |        |      |            |           |      |            |        |      |              |              |      |             |         |      |              |          |      |              |          |      |             |          |      |             |                  |      |             |                    |      |             |        |      |             |         |      |             |            |      |            |         |      |            |              |      |              |      |      |             |           |      |            |            |      |             |      |      |             |       |      |             |         |      |            |       |      |             |              |      |            |              |      |             |       |      |             |                 |      |             |           |      |            |            |      |             |        |      |            |                |      |            |  |      |      |             |    |         |             |              |      |            |                    |      |            |            |      |            |              |      |            |                       |      |            |           |      |            |                |      |            |                                |      |            |
| ./2014  | 4096        | Aug 8 2014   |             |    |         |              |            |      |             |        |      |             |         |      |             |          |      |             |        |      |            |           |      |            |        |      |              |              |      |             |         |      |              |          |      |              |          |      |             |          |      |             |                  |      |             |                    |      |             |        |      |             |         |      |             |            |      |            |         |      |            |              |      |              |      |      |             |           |      |            |            |      |             |      |      |             |       |      |             |         |      |            |       |      |             |              |      |            |              |      |             |       |      |             |                 |      |             |           |      |            |            |      |             |        |      |            |                |      |            |  |      |      |             |    |         |             |              |      |            |                    |      |            |            |      |            |              |      |            |                       |      |            |           |      |            |                |      |            |                                |      |            |
| ./2014_Energia  | 4096        | Nov 9 2014   |             |    |         |              |            |      |             |        |      |             |         |      |             |          |      |             |        |      |            |           |      |            |        |      |              |              |      |             |         |      |              |          |      |              |          |      |             |          |      |             |                  |      |             |                    |      |             |        |      |             |         |      |             |            |      |            |         |      |            |              |      |              |      |      |             |           |      |            |            |      |             |      |      |             |       |      |             |         |      |            |       |      |             |              |      |            |              |      |             |       |      |             |                 |      |             |           |      |            |            |      |             |        |      |            |                |      |            |  |      |      |             |    |         |             |              |      |            |                    |      |            |            |      |            |              |      |            |                       |      |            |           |      |            |                |      |            |                                |      |            |
| Name  | Size        | Modify time  |             |    |         |              |            |      |             |        |      |             |         |      |             |          |      |             |        |      |            |           |      |            |        |      |              |              |      |             |         |      |              |          |      |              |          |      |             |          |      |             |                  |      |             |                    |      |             |        |      |             |         |      |             |            |      |            |         |      |            |              |      |              |      |      |             |           |      |            |            |      |             |      |      |             |       |      |             |         |      |            |       |      |             |              |      |            |              |      |             |       |      |             |                 |      |             |           |      |            |            |      |             |        |      |            |                |      |            |  |      |      |             |    |         |             |              |      |            |                    |      |            |            |      |            |              |      |            |                       |      |            |           |      |            |                |      |            |                                |      |            |
| ..  | UP--DIR     | May 22 2015  |             |    |         |              |            |      |             |        |      |             |         |      |             |          |      |             |        |      |            |           |      |            |        |      |              |              |      |             |         |      |              |          |      |              |          |      |             |          |      |             |                  |      |             |                    |      |             |        |      |             |         |      |             |            |      |            |         |      |            |              |      |              |      |      |             |           |      |            |            |      |             |      |      |             |       |      |             |         |      |            |       |      |             |              |      |            |              |      |             |       |      |             |                 |      |             |           |      |            |            |      |             |        |      |            |                |      |            |  |      |      |             |    |         |             |              |      |            |                    |      |            |            |      |            |              |      |            |                       |      |            |           |      |            |                |      |            |                                |      |            |
| ./simpleFoam  | 4096        | Jul 7 2015   |             |    |         |              |            |      |             |        |      |             |         |      |             |          |      |             |        |      |            |           |      |            |        |      |              |              |      |             |         |      |              |          |      |              |          |      |             |          |      |             |                  |      |             |                    |      |             |        |      |             |         |      |             |            |      |            |         |      |            |              |      |              |      |      |             |           |      |            |            |      |             |      |      |             |       |      |             |         |      |            |       |      |             |              |      |            |              |      |             |       |      |             |                 |      |             |           |      |            |            |      |             |        |      |            |                |      |            |  |      |      |             |    |         |             |              |      |            |                    |      |            |            |      |            |              |      |            |                       |      |            |           |      |            |                |      |            |                                |      |            |
| ./shallowWaterFoam  | 4096        | Jul 7 2015   |             |    |         |              |            |      |             |        |      |             |         |      |             |          |      |             |        |      |            |           |      |            |        |      |              |              |      |             |         |      |              |          |      |              |          |      |             |          |      |             |                  |      |             |                    |      |             |        |      |             |         |      |             |            |      |            |         |      |            |              |      |              |      |      |             |           |      |            |            |      |             |      |      |             |       |      |             |         |      |            |       |      |             |              |      |            |              |      |             |       |      |             |                 |      |             |           |      |            |            |      |             |        |      |            |                |      |            |  |      |      |             |    |         |             |              |      |            |                    |      |            |            |      |            |              |      |            |                       |      |            |           |      |            |                |      |            |                                |      |            |
| ./pisoFoam  | 4096        | Jul 7 2015   |             |    |         |              |            |      |             |        |      |             |         |      |             |          |      |             |        |      |            |           |      |            |        |      |              |              |      |             |         |      |              |          |      |              |          |      |             |          |      |             |                  |      |             |                    |      |             |        |      |             |         |      |             |            |      |            |         |      |            |              |      |              |      |      |             |           |      |            |            |      |             |      |      |             |       |      |             |         |      |            |       |      |             |              |      |            |              |      |             |       |      |             |                 |      |             |           |      |            |            |      |             |        |      |            |                |      |            |  |      |      |             |    |         |             |              |      |            |                    |      |            |            |      |            |              |      |            |                       |      |            |           |      |            |                |      |            |                                |      |            |
| ./pimpleFoam  | 4096        | Jul 7 2015   |             |    |         |              |            |      |             |        |      |             |         |      |             |          |      |             |        |      |            |           |      |            |        |      |              |              |      |             |         |      |              |          |      |              |          |      |             |          |      |             |                  |      |             |                    |      |             |        |      |             |         |      |             |            |      |            |         |      |            |              |      |              |      |      |             |           |      |            |            |      |             |      |      |             |       |      |             |         |      |            |       |      |             |              |      |            |              |      |             |       |      |             |                 |      |             |           |      |            |            |      |             |        |      |            |                |      |            |  |      |      |             |    |         |             |              |      |            |                    |      |            |            |      |            |              |      |            |                       |      |            |           |      |            |                |      |            |                                |      |            |
| ./nonNewtonianIcoFoam   | 4096        | Jul 7 2015   |             |    |         |              |            |      |             |        |      |             |         |      |             |          |      |             |        |      |            |           |      |            |        |      |              |              |      |             |         |      |              |          |      |              |          |      |             |          |      |             |                  |      |             |                    |      |             |        |      |             |         |      |             |            |      |            |         |      |            |              |      |              |      |      |             |           |      |            |            |      |             |      |      |             |       |      |             |         |      |            |       |      |             |              |      |            |              |      |             |       |      |             |                 |      |             |           |      |            |            |      |             |        |      |            |                |      |            |  |      |      |             |    |         |             |              |      |            |                    |      |            |            |      |            |              |      |            |                       |      |            |           |      |            |                |      |            |                                |      |            |
| ./icoFoam   | 4096        | Jul 7 2015   |             |    |         |              |            |      |             |        |      |             |         |      |             |          |      |             |        |      |            |           |      |            |        |      |              |              |      |             |         |      |              |          |      |              |          |      |             |          |      |             |                  |      |             |                    |      |             |        |      |             |         |      |             |            |      |            |         |      |            |              |      |              |      |      |             |           |      |            |            |      |             |      |      |             |       |      |             |         |      |            |       |      |             |              |      |            |              |      |             |       |      |             |                 |      |             |           |      |            |            |      |             |        |      |            |                |      |            |  |      |      |             |    |         |             |              |      |            |                    |      |            |            |      |            |              |      |            |                       |      |            |           |      |            |                |      |            |                                |      |            |
| ./boundaryFoam  | 4096        | Jul 7 2015   |             |    |         |              |            |      |             |        |      |             |         |      |             |          |      |             |        |      |            |           |      |            |        |      |              |              |      |             |         |      |              |          |      |              |          |      |             |          |      |             |                  |      |             |                    |      |             |        |      |             |         |      |             |            |      |            |         |      |            |              |      |              |      |      |             |           |      |            |            |      |             |      |      |             |       |      |             |         |      |            |       |      |             |              |      |            |              |      |             |       |      |             |                 |      |             |           |      |            |            |      |             |        |      |            |                |      |            |  |      |      |             |    |         |             |              |      |            |                    |      |            |            |      |            |              |      |            |                       |      |            |           |      |            |                |      |            |                                |      |            |
| ./adjointShapeOptimizationFoam  | 4096        | Jul 7 2015   |             |    |         |              |            |      |             |        |      |             |         |      |             |          |      |             |        |      |            |           |      |            |        |      |              |              |      |             |         |      |              |          |      |              |          |      |             |          |      |             |                  |      |             |                    |      |             |        |      |             |         |      |             |            |      |            |         |      |            |              |      |              |      |      |             |           |      |            |            |      |             |      |      |             |       |      |             |         |      |            |       |      |             |              |      |            |              |      |             |       |      |             |                 |      |             |           |      |            |            |      |             |        |      |            |                |      |            |  |      |      |             |    |         |             |              |      |            |                    |      |            |            |      |            |              |      |            |                       |      |            |           |      |            |                |      |            |                                |      |            |
- Bottom Panel:** A status bar with keyboard shortcuts: 1 Help, 2 menu, 3 new, 4 edit, 5 copy, 6 ren/mv, 7 lkr, 8 delete, 9 pull/dn, 10 quit. A hint below the terminal reads: 'Hint: Find File: you can work on the files found using the Panelize button, sergei.strijhak@vcn.unicluster.ru:/lustre/unicluster/home/sergei.strijhak\$'.

# Different solvers in OpenFOAM

`$FOAM_APP/solvers`

DNS

dnsFoam

basic

laplacianFoam, scalarTransportFoam

combustion

reactingFoam, fireFoam

compressible

sonicFoam, rhoCentralFoam

discreteMethods

dsmcFoam

electromagnetics

electrostaticFoam

financial

financialFoam

heatTransfer

buoyantPimpleFoam, chtMultiRegionFoam

incompressible

icoFoam, pisoFoam

lagrangian

reactingParcelFilmFoam

multiphase

interFoam, cavitatingFoam

stressAnalysis

solidDisplacementFoam

*Solver — numerical model for integration of partial differential equations, which is based on finite volume method, written on C++ language*

*Two different versions of OpenFOAM: [www.openfoam.org](http://www.openfoam.org) and [www.extend-project.de](http://www.extend-project.de)*

# Interaction of liquid metal droplets with liquid layer

Project with ASML company

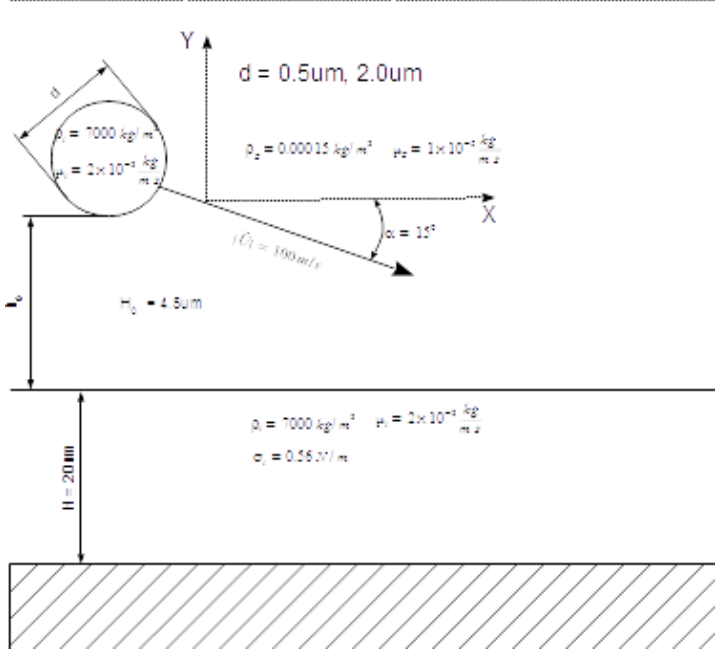
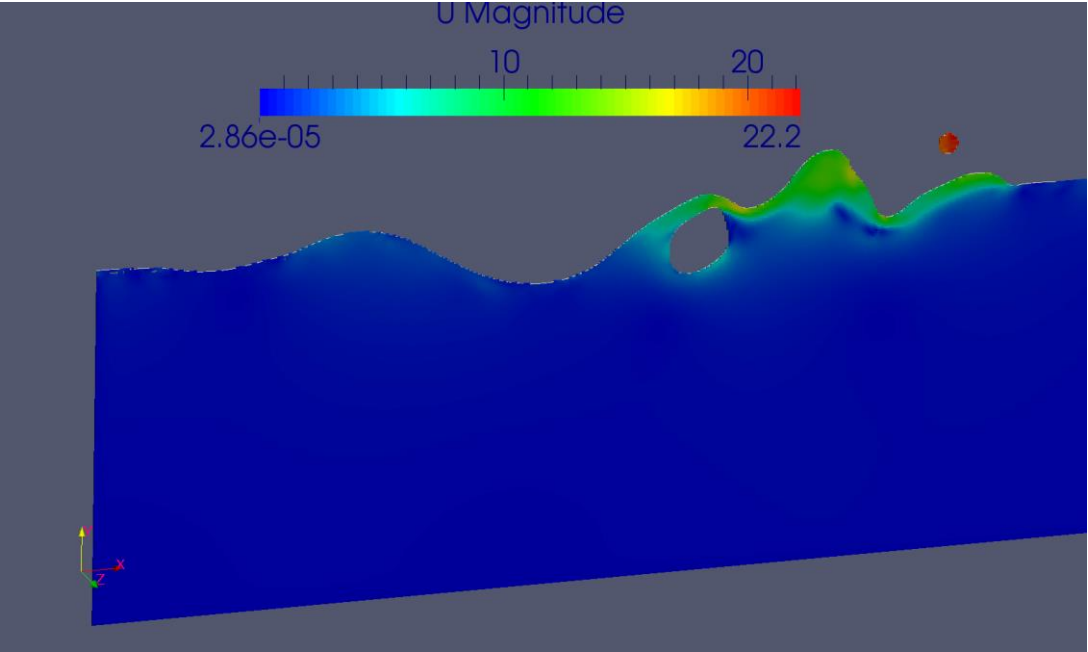

Cavitation with external flow.  
Blue color shows cavitation cavity.

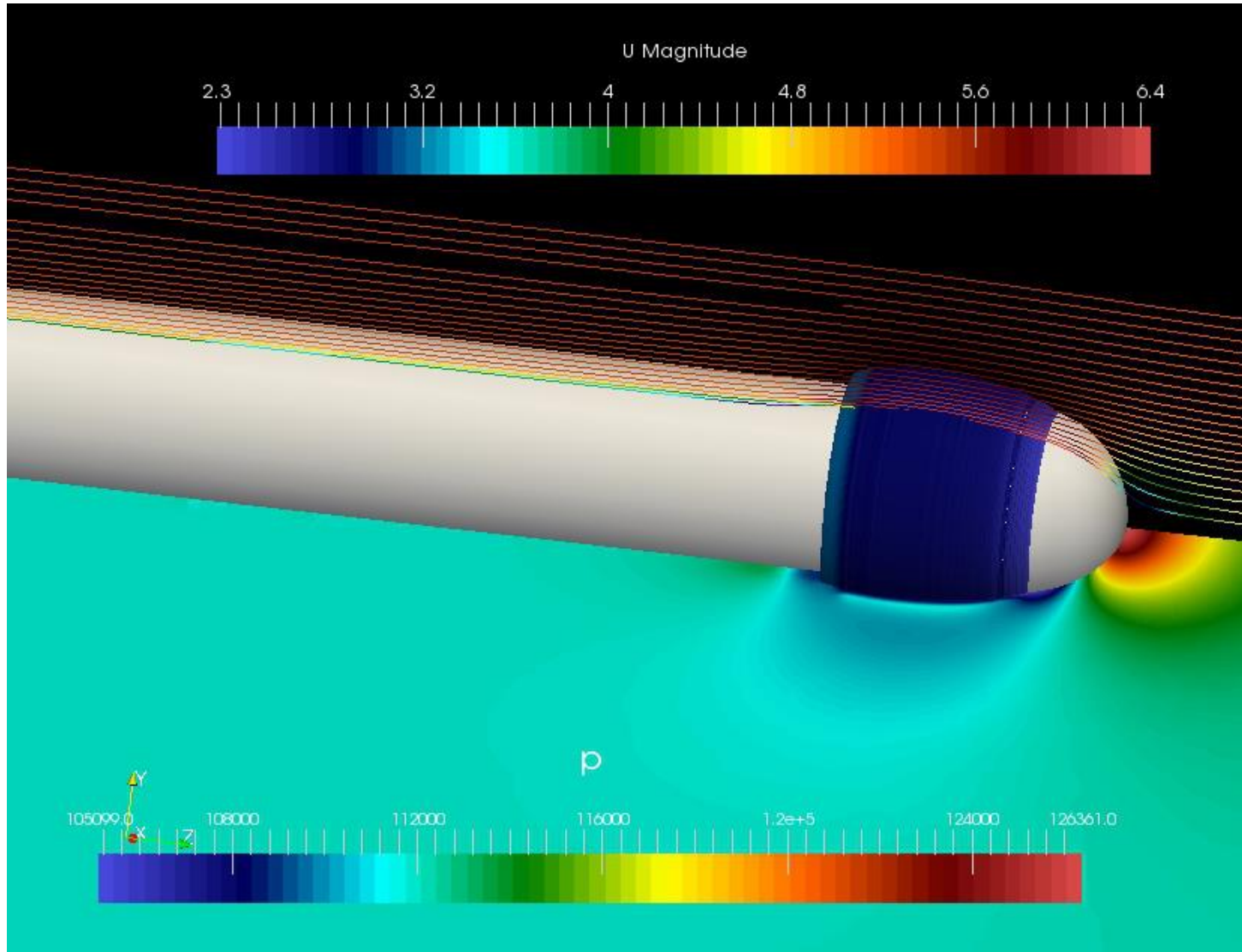

# Turbomachinery Flows: Simulation of Supersonic Radial Compressor

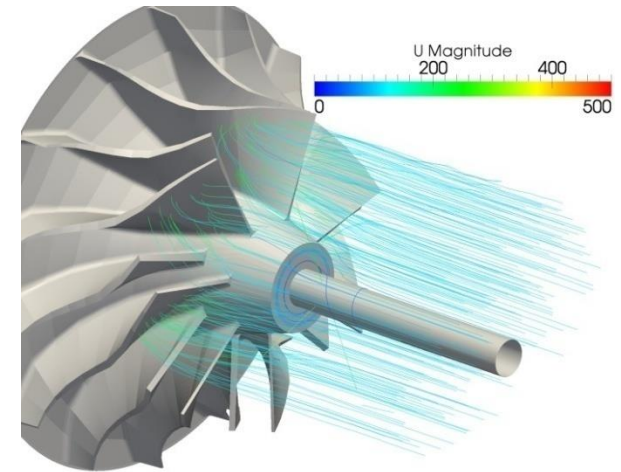
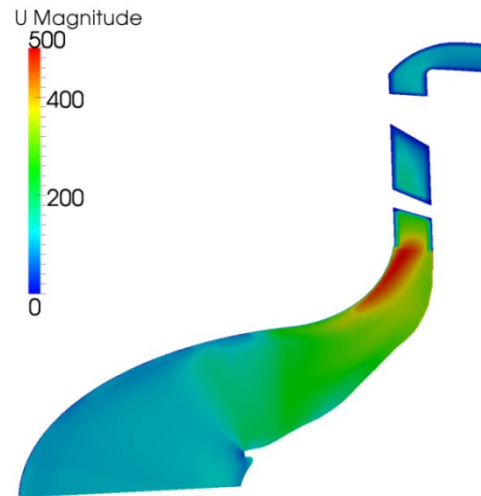
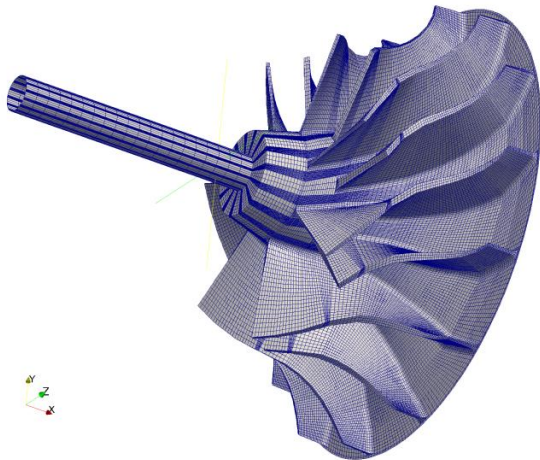
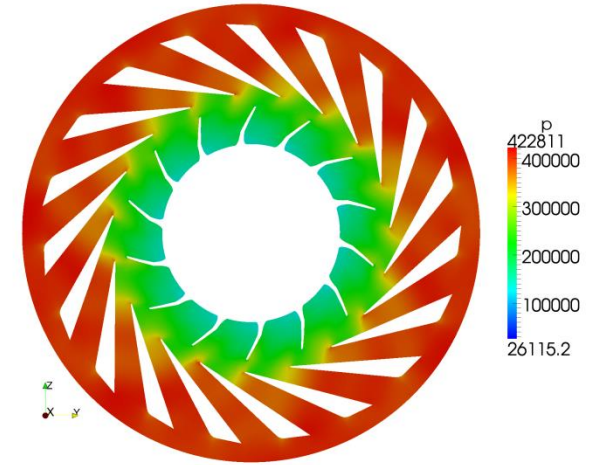
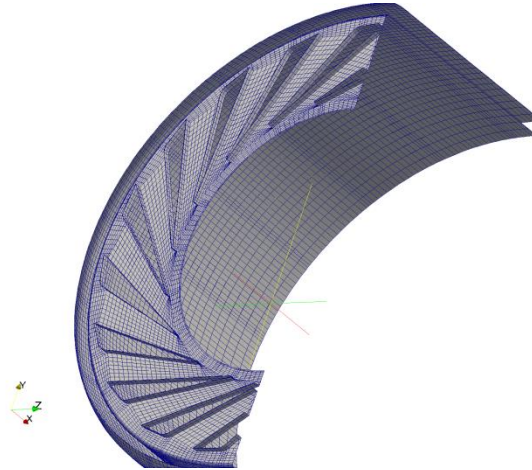
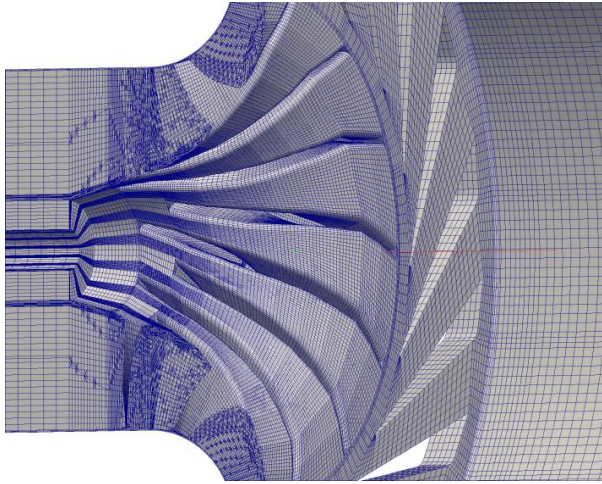

Turbulent Flow with LES model. Solver in OpenFOAM:  
mySonicDyMfoam. Number of cells: 26 111 120



# External aerodynamics and computational aeracoustics

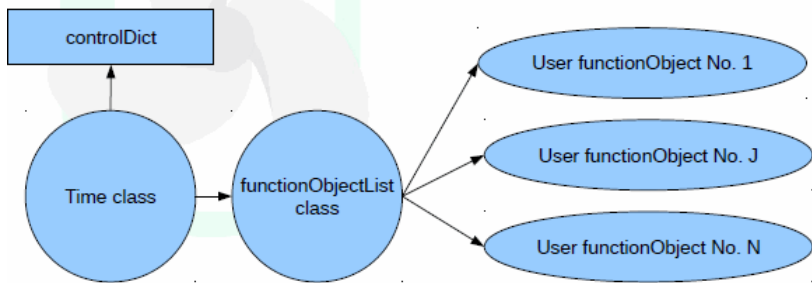

$$p'(\vec{x}, t) = \frac{1}{4\pi c_0 r^2} \left[ \frac{\partial F_i}{\partial t} + \frac{c_0 F_i}{r} \right]$$

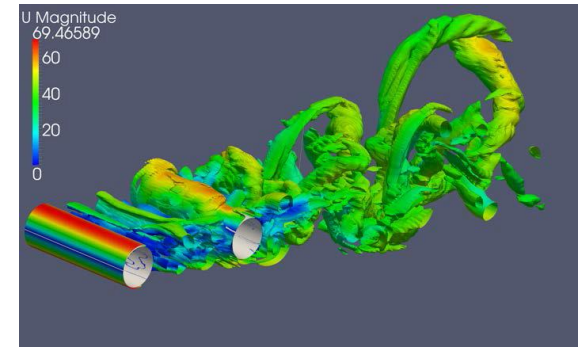
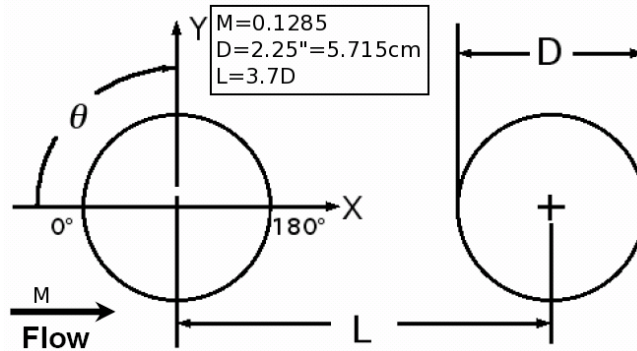
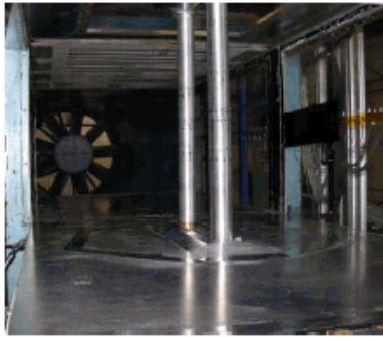

Test case : tandem cylinders

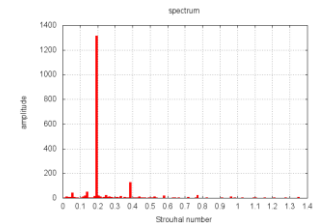
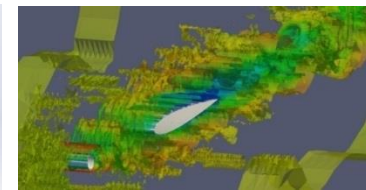
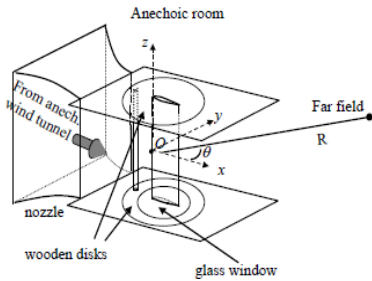

**Solver : pisoFoam + LES model + Libacoustics.so library**

**New Project for 2016: Hybrid CAA solver with lagrangianCentralFoam and BEM++**

# Ship Hydrodynamics

Different Re (Reynolds) and Fr (Froude) numbers.

Solver in OpenFOAM: interFoam + k-omega SST turbulence model

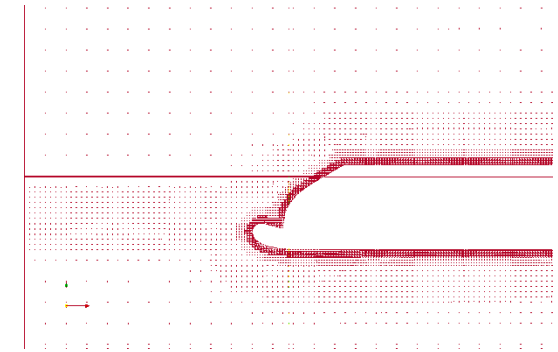
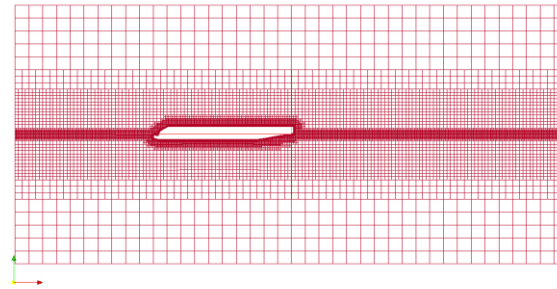
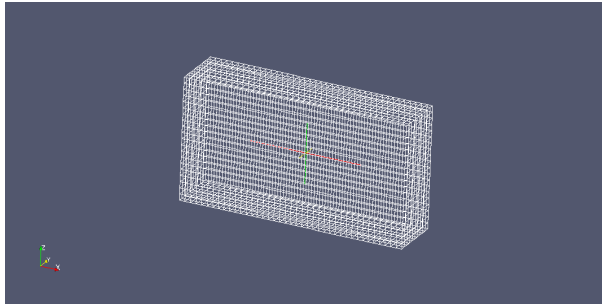

Domain: 1000 m\*250 m\* 510 m.  $L_{ship}=6$  m.

Number of cells:  $\sim 4\,000\,000 - 96\,000\,000$

Definition of forces and moments

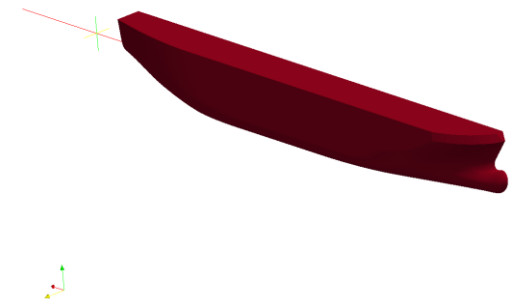
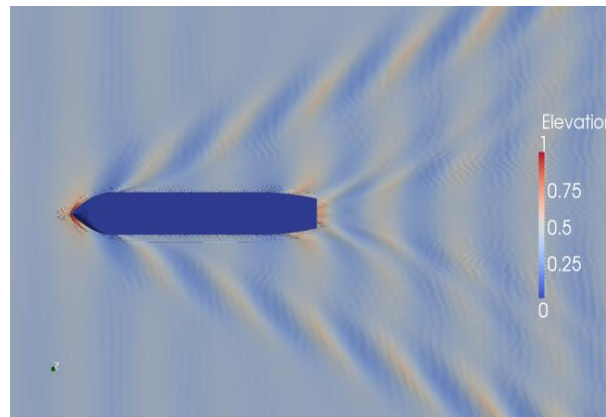
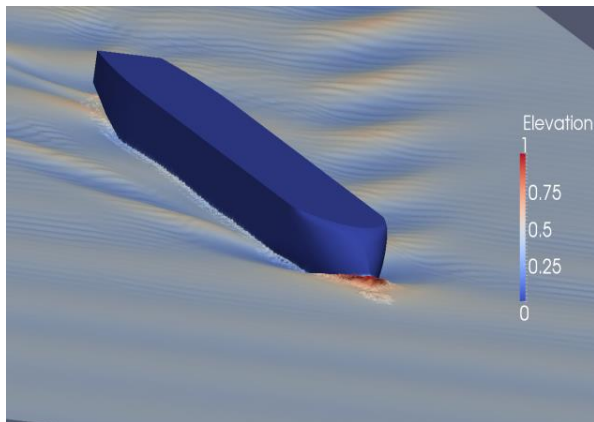

# Research of droplet impacts on the large Froude numbers

Main goals of research:

- to investigate the possibility of different open-source packages to solve problems of droplet impact;
- to make a numerical research of different regimes of droplet impact to the deep pool or to solid surface with different contact angles.

Parts of research:

- investigation of droplet impact to the deep pool;
- investigation of droplet impact to the solid surface with different values of contact angle;
- study of heat transfer effects when droplet falls onto the solid surface.

Range of dimensionless criteria:

- $Fr = \frac{U^2}{gd} > 10^5$
- $Re = \frac{\rho U d}{\mu} = 400 \dots 3000$
- $We = \frac{\rho U^2 d}{\sigma} = 10^2 \dots 10^4$

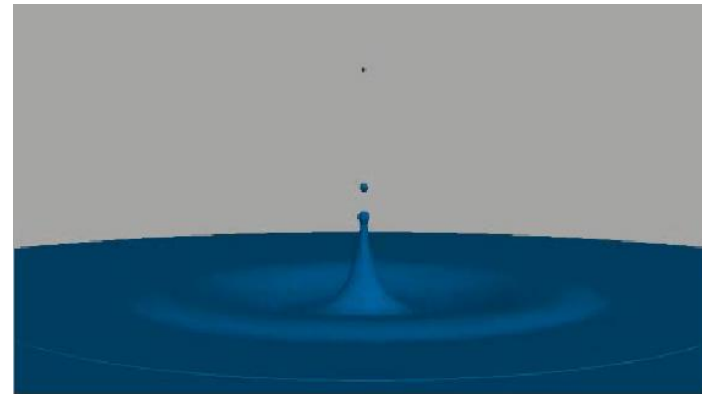

Fields of temperature for solder torch  $V=10 \text{ m/c}$ .

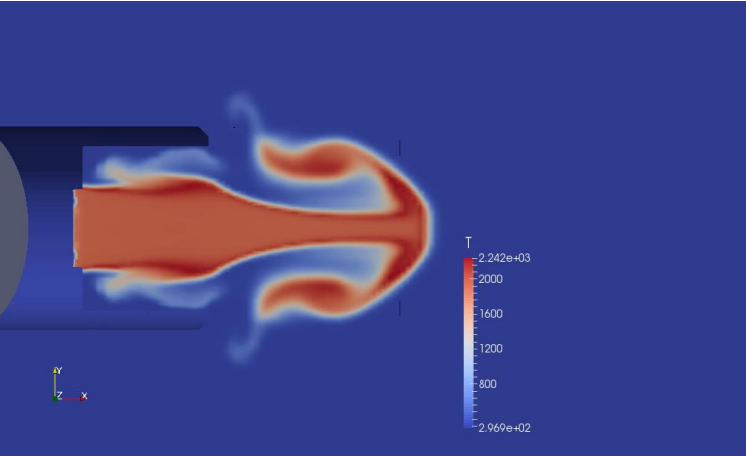

Grid - 8mln. cells. Time  $T1= 0,001 \text{ c}$ .

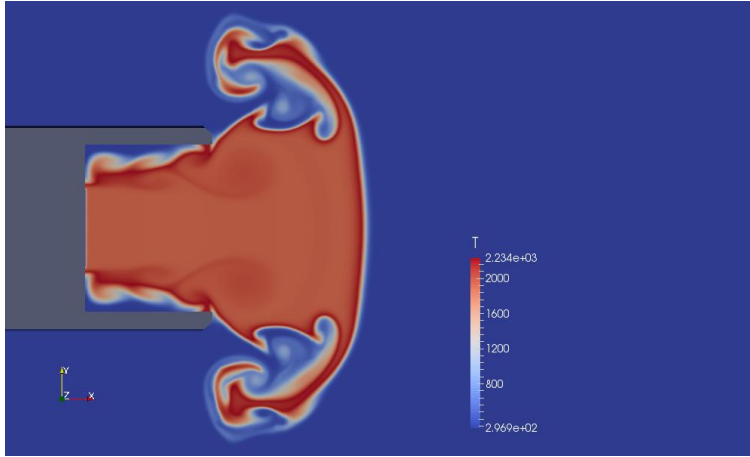

Grid — 5 mln. cells. Time  $T1= 0,001$

c.

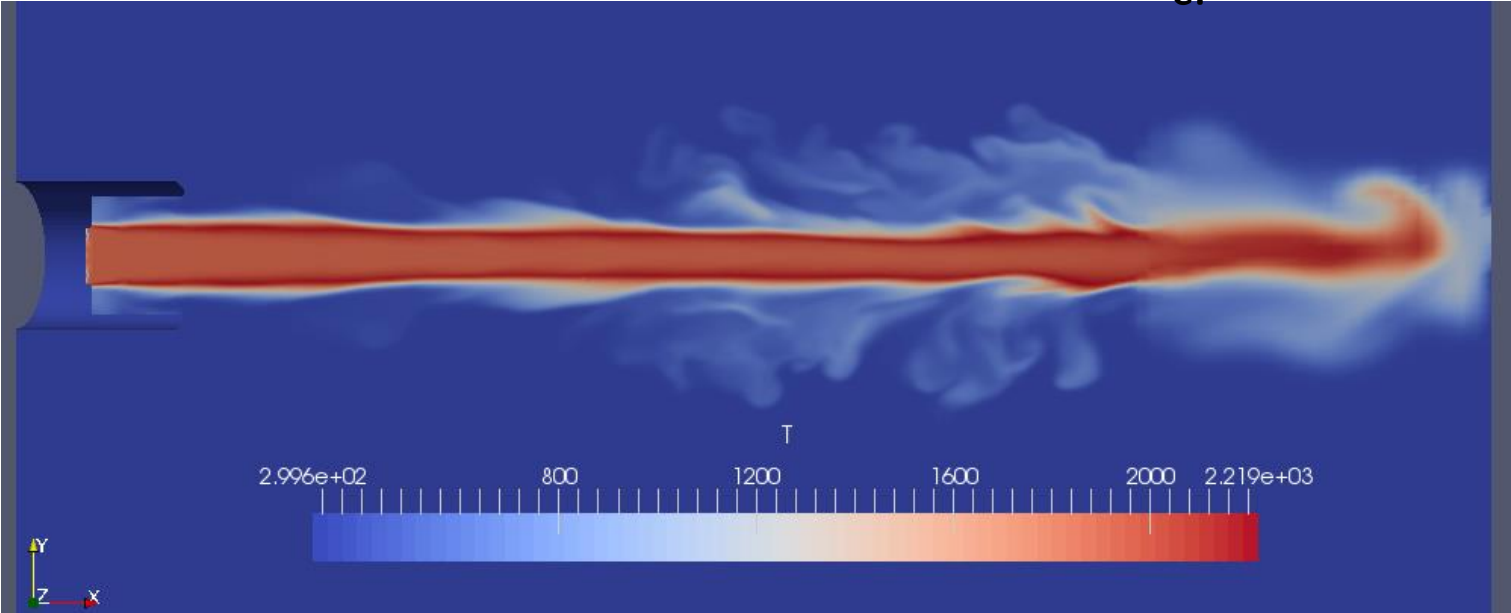

Grid — 8 mln. cells. Time  $T1= 0,01 \text{ c}$ .

# Project: Cluster for analysis of Big Data

1) Algorithm POD (Lumley 1970; Sirovich 1987) Proper Orthogonal Decomposition:

- Simple algorithm which depends from snapshots.
- SVD decomposition.
- Orthogonalization in space

2) Algorithm DMD (Rowley 2009; Schmid 2010) Dynamic mode decomposition:

- Time snapshots.
- Orthogonalization in time.

3) Search and group of data

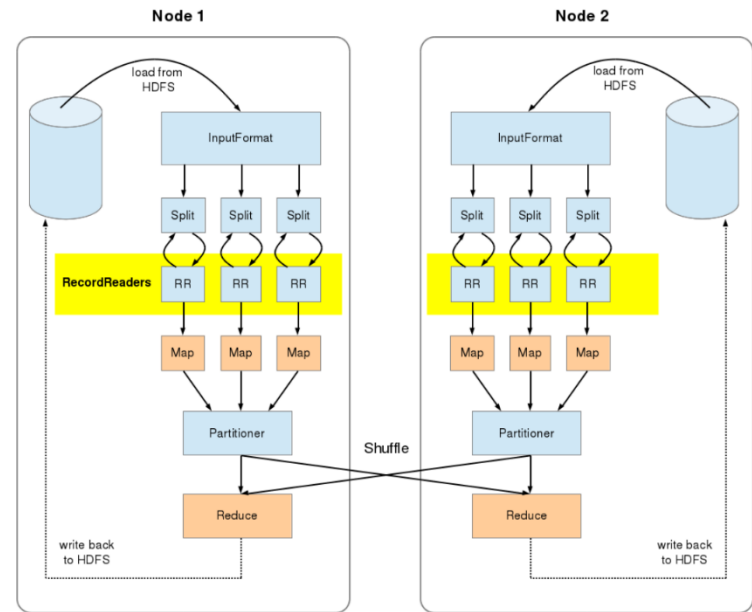
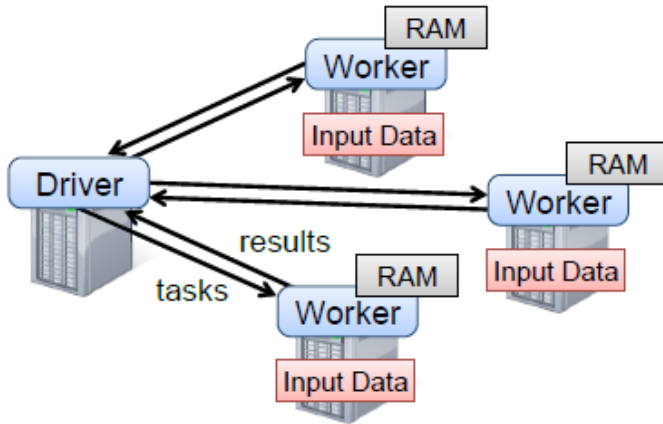

Deployment of Apache Spark cluster in ISP RAS

Hadoop/Mapreduce cluster

# Web-laboratory UniCFD=Community



The main goal – creating the community of users and developers

2011-2015: Workshops, Users' trainings, Conferences, Summer schools in Moscow State University (MSU supercomputer Academy)

# UPC: cfd for urban drainage

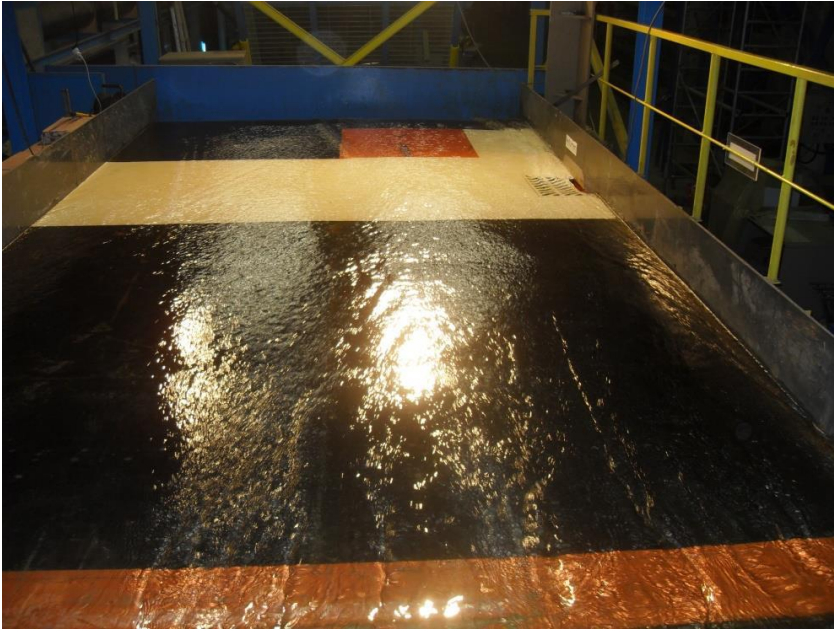

Urban Drainage platform - Hydraulics Laboratory in UPC

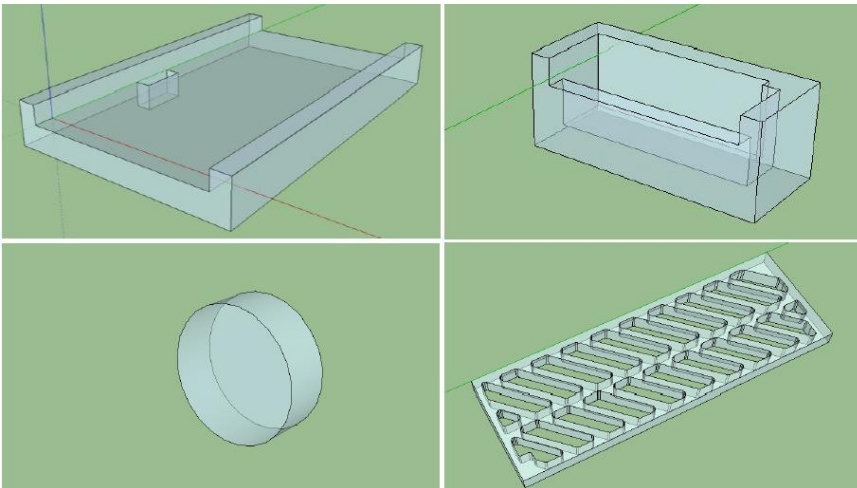

Ph.D student : Jackson Tellez

Platform Dim: 5.5m x 3m. Flow rate: 100 l/s.

Different conventional Grates

OpenFOAM: interFoam, porousinterFoam

The goal: 3D turbulent flow simulation, definition of velocity fields, pressure drop, flow rate, particle trajectories

New: Possible implementation of PANS (Partially-averaged Navier Stokes) model in OpenFOAM

# Experimentas of fractal grates and oscillation grates ( UPC, Barcelona, Prof. J.M. Redondo)

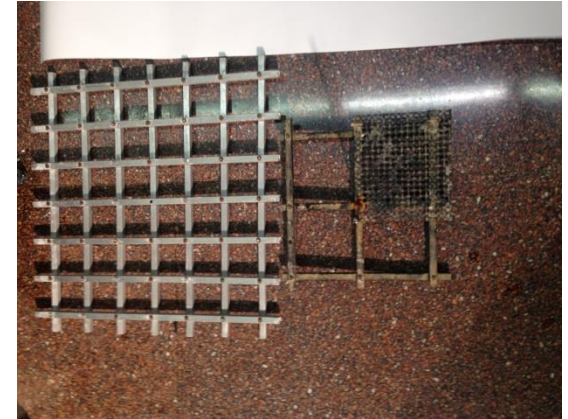

Two scale grate



Sierpinski grate



# Numerical Domain

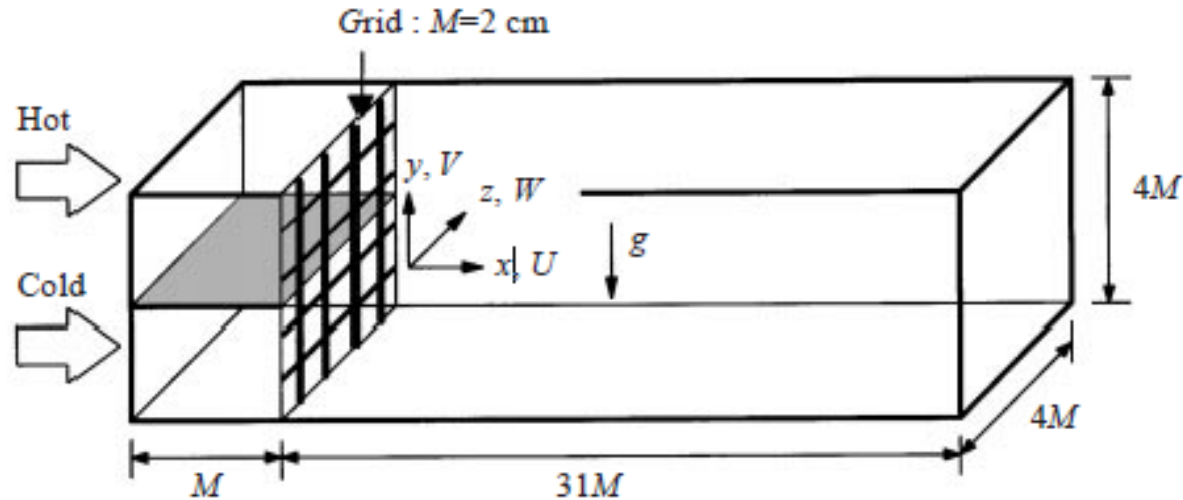

The mesh size of grid:  
 $M = 2.0 \times 10^{-2}$  m  
 Diameter of the rod  
 $d = 3.0 \times 10^{-3}$  m

The computational domain was  $640 \times 80 \times 80$  mm ( $32M \times 4M \times 4M$ ) in the streamwise, vertical and spanwise directions

The numbers of grid points used here were  $640 \times 160 \times 160$  in the streamwise, vertical and spanwise directions and therefore the grid spacings were  $1.0 \times 10^{-3}$  m in the streamwise direction and  $5.0 \times 10^{-4}$  m in the vertical and spanwise directions

A square turbulence-generating grid, on which the velocity components are set to zero, was located  $2.0 \times 10^{-2}$  m downstream from the entrance

# Biplane grid

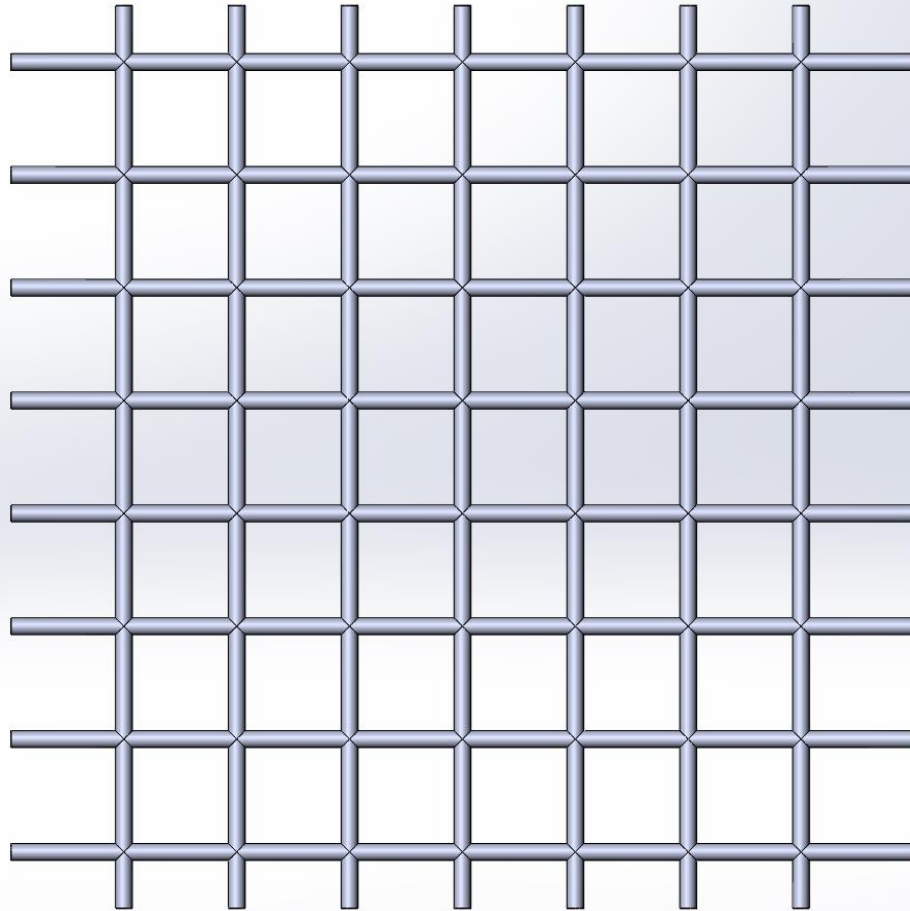

Fractal Cross grid ( $T=0.91$  m,  $t_{\max}=62$  mm,  $t_{\min}=18.78$ mm,  $w=5$  mm)

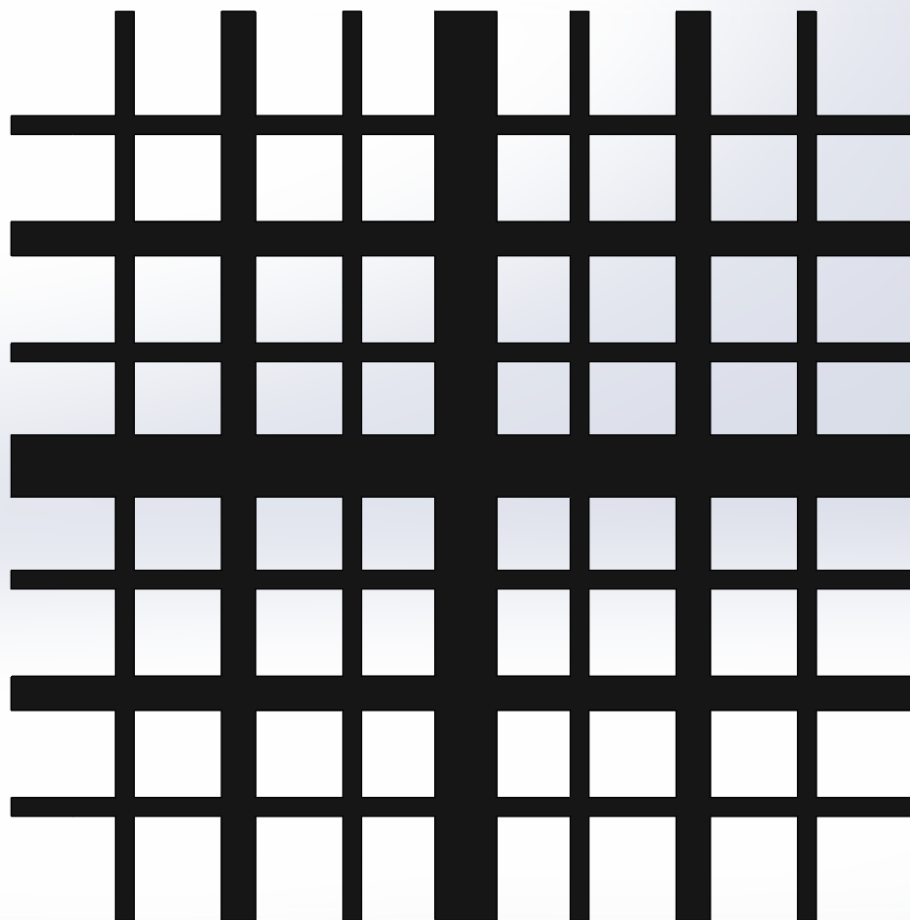

# Turbulence modeling

RANS, LES, DNS

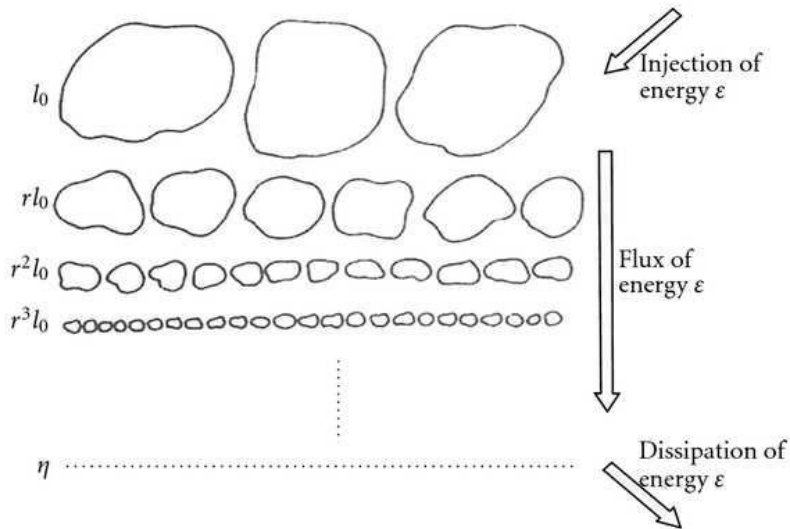

The Kolmogorov (1941) -5/3 Law

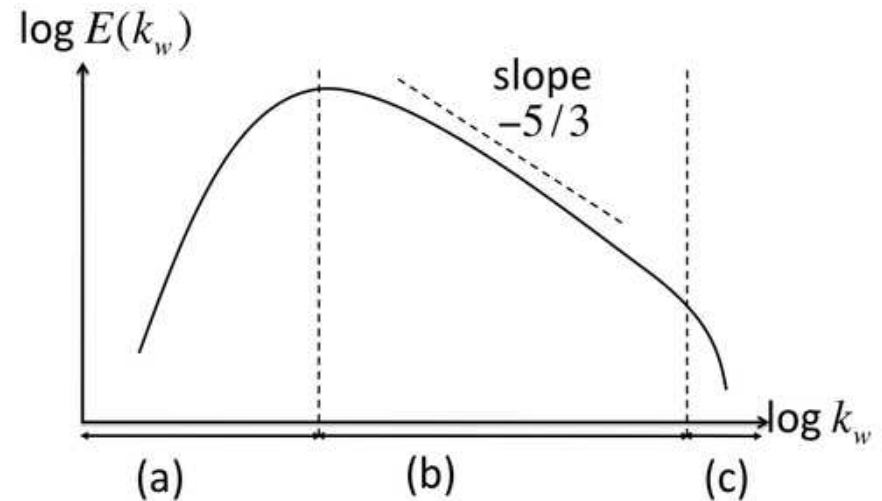

Fig. : Energy cascade and spectrum

- DES is a hybrid LES/RANS approach.
- Zonal approaches, switch the solving equations during the simulation or inside the domain.
- Fixed zonal approach, the RANS zones are defined a priori (close to wall)
- PANS is a hybrid DNS/RANS approach.

# PANS model

Partially-averaged Navier Stokes (PANS) is a suite of turbulence closures of various modeled-to-resolved scale ratios ranging from Reynolds-averaged Navier Stokes (RANS) to Navier-Stokes (Direct Numerical Simulations).

The objective of PANS, like hybrid models, is to resolve large scale structures at reasonable computational expense.

The cut-off lengthscale in PANS is quantified by two parameters: the unresolved-to-total ratios of kinetic energy ( $f_k$ ) and dissipation ( $f_\epsilon$ ).

The unresolved stress is modeled with the Boussinesq approximation and modeled transport equations are solved for the unresolved kinetic energy and dissipation

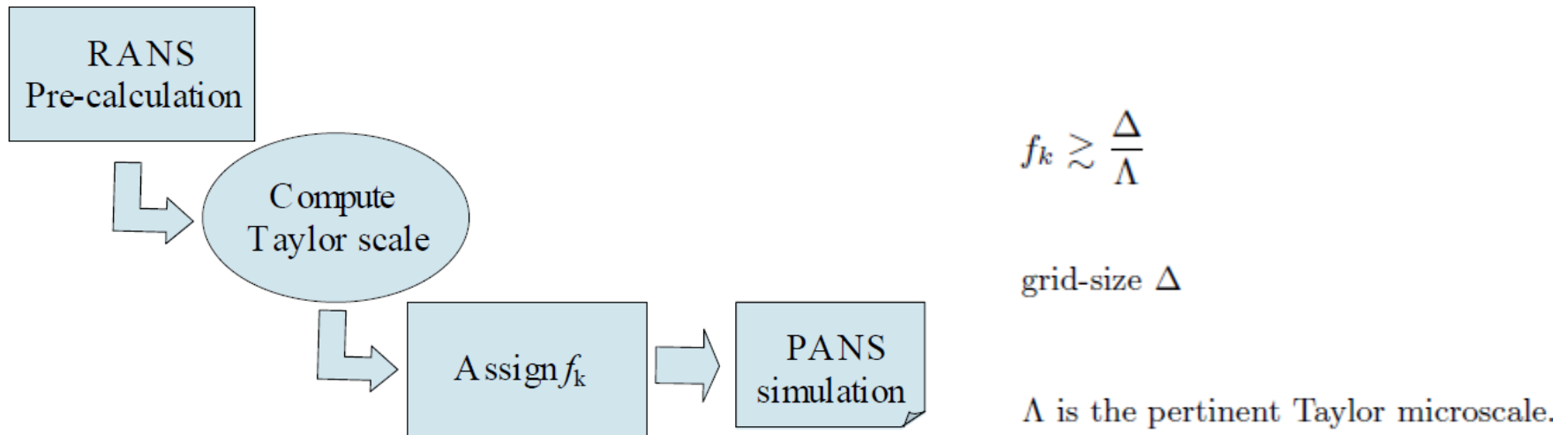

Figure 1. Four-step implementation scheme.

## PANS is a hybrid RANS/DNS approach

### URANS $k - \varepsilon$ closure equation system

$$\frac{\partial k}{\partial t} + U_j \frac{\partial k}{\partial x_j} = P_k - \varepsilon + \frac{\partial}{\partial x_j} \left[ \left( \nu + \frac{\nu_t}{\sigma_k} \right) \frac{\partial k}{\partial x_j} \right]$$

$$\frac{\partial \varepsilon}{\partial t} + U_j \frac{\partial \varepsilon}{\partial x_j} = C_{1\varepsilon} \frac{\varepsilon}{k} (P_k) - C_{2\varepsilon} \frac{\varepsilon^2}{k} + \frac{\partial}{\partial x_j} \left[ \left( \nu + \frac{\nu_t}{\sigma_\varepsilon} \right) \frac{\partial \varepsilon}{\partial x_j} \right]$$

- $C_{1\varepsilon} = 1.44$ ,  $C_{2\varepsilon} = 1.92$ ,  $\sigma_\varepsilon = 1.3$  and  $\sigma_k = 1$
- $\nu_t$  is updated every time step as

$$\nu_t = C_\mu \frac{k^2}{\varepsilon}; \quad C_\mu = 0.09$$

- The method can catch only large oscillation such as vortex shedding

# PANS cfd examples

(Chalmers Technology University, Texas A&M University)

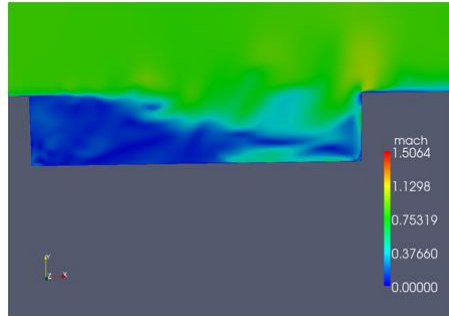
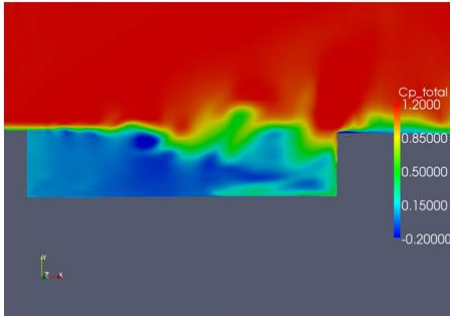
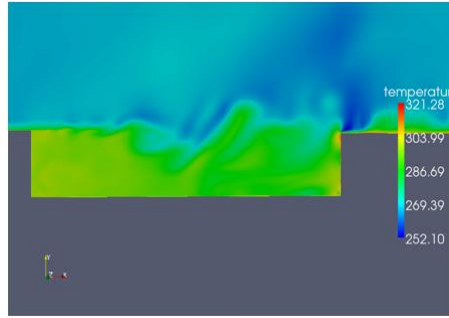
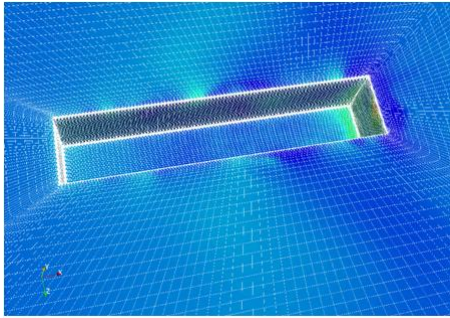

Transonic 3D cavity

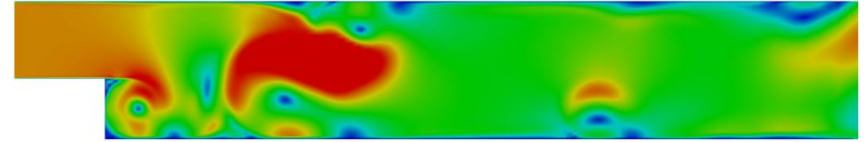

Instantaneous velocity field.

Fixed Fk PANS

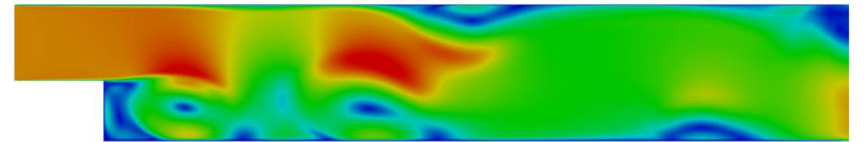

Instantaneous velocity field.

varying Fk PANS

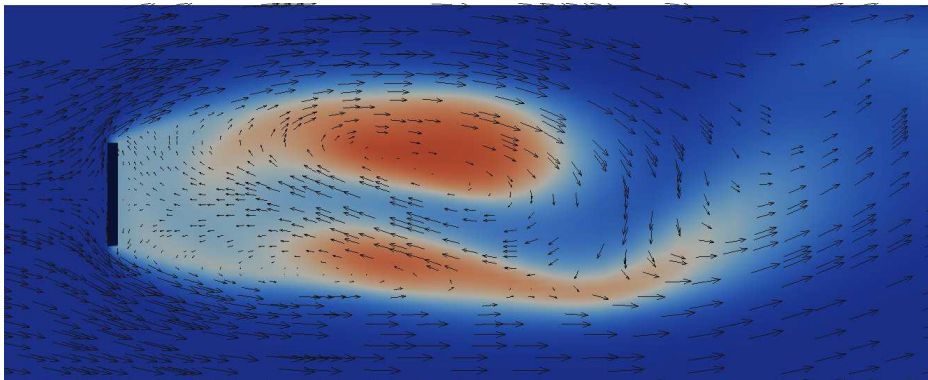

simulation cavitation in 2d flat plate

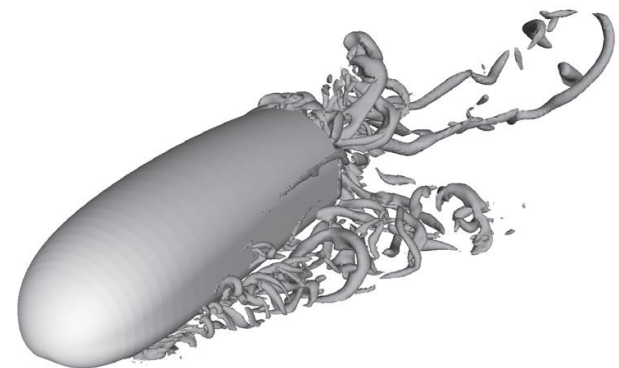

flow around generic vehicle

# Conclusions

- There is a web laboratory in ISP RAS and we use different Open Source software
- pisoCentralFoam with different modifications is available on [github.com](https://github.com)
- We try to do a research in fluid dynamics
- We prepared different courses and trainings with Salome/OpenFoam/Paraview
- Deployment of UniHUB in different organizations in Russia
- Our solver is a good start point for scientific collaboration with other different groups! 😊